

EN

MiniOPD EXP
INSTALLATION INSTRUCTIONS



© TDE Macno SPA - Cod. MAMOPD0000E0 rev. 1.7

TDE MACNO

Tecnologie Digitali Elettroniche S.p.A.

Excellence in the Control

INDEX

1	INTRODUCTION	3
2	WARRANTY	4
3	CE MARKING / DATA PLATE	5
4	GENERAL INFORMATION	6
4.1	IMPORTANCE OF THIS MANUAL	6
4.2	CONSULTATION NOTES.....	7
4.2.1	Addressees of this Manual (Authorized Operators).....	7
4.2.2	“Device Off” Status.....	8
4.3	ABBREVIATIONS	8
4.4	ALL RIGHTS RESERVED.....	9
5	TECHNICAL DESCRIPTION	10
5.1	NAME OF THE DEVICE	10
5.2	OPEN DRIVE EXP CODE.....	11
5.3	COMPONENT NAMES AND SIZES	12
5.4	TECHNICAL DATA	15
5.5	INTENDED USE	17
5.6	OPERATIONAL STEPS	18
5.7	USE LIMITATIONS	18
6	TRANSPORTATION AND HANDLING.....	19
6.1	TRANSPORTATION	19
6.2	PACKAGING	19
6.3	LIFTING AND HANDLING THE PACKAGING	19
6.4	UNPACKING.....	19
6.5	STORAGE.....	19
6.5.1	Environmental Storage Conditions.....	19
6.5.2	Recovery Procedure After Storage	20
7	INSTALLATION	21
7.1	INSTALLATION.....	21
7.1.1	Feedback Board Replacement.....	23
7.2	ELECTRICAL CONNECTIONS.....	24
7.2.1	Power Stage	26
7.2.2	Mains Connection	27
7.2.3	Pre-Charge (Soft Start)	27
7.2.4	Connecting the Motor	28
7.2.5	Grounding the Drive	29
7.2.6	Braking.....	29
7.2.7	Connection Via Shared Bus	30
7.2.8	Power Connectios Layout	31
7.2.9	Logic connections	34
7.2.10	Digital and Analog Logic Connections	35
7.2.11	Feedback Options	43
7.3	OPTOISOLATED SERIAL LINE RS485.....	48

7.4	LINE INPUT	50
7.5	LINE OUTPUT	51
8	CONNECTION/FIXING SHIELDS	52
9	SAFETY	53
9.1	REFERENCE DIRECTIVES AND STANDARDS	53
9.2	INTERFERENCE-SUPPRESSION MEASURES	54

1 INTRODUCTION

Dear Customer,

Thank you for the trust you have placed in us by purchasing our new motor drive “**MiniOPD EXP**”.

We hope that this product meets all your present and future expectations.

Our technical staff is at your disposal for any further information.

This instruction manual contains all the instructions needed to install the equipment.

2 WARRANTY

- 1) Within the limits of this Warranty, the undersigned Manufacturer undertakes to repair any defects in workmanship that may be detected during the warranty period which is 12 (twelve) months from the date of sale.
- 2) This Warranty shall be void if the Buyer does not follow all the instructions described in these "Installation Instructions".
- 3) In order to avail itself of its rights under the Warranty, Buyer must immediately notify the Manufacturer of any defects and allow the Manufacturer to inspect and remedy defects, if deemed necessary.
- 4) Buyer shall bear all transportation costs of shipment of the defective part, covered by the provisions of this Warranty, to the Manufacturer for repair or replacement, as well as the costs of return of such part.
By delivering a duly repaired or replaced part to the Buyer, the Manufacturer shall be deemed to have fulfilled its warranty obligation under this clause.
- 5) Within the warranty period referred to in clause 1) the Manufacturer shall bear all labor costs for the repair of the defective part.
If repairs or replacements are to be carried out at the Customer's premises, all travel and living expenses for the Manufacturer's personnel shall be borne by the Buyer.
- 6) Breakdowns or failures due to misuse, unskilfulness or fortuitous event or to an event for which the User is responsible in any way whatsoever, whether through its own fault or through the fault of third parties, or due to alterations or repairs made by the Buyer without the prior written permission of the Manufacturer, regardless of whether there is a connection between such alterations or repairs and the defects detected, are not covered by this Warranty.
- 7) It is expressly agreed that the Manufacturer shall in no event be liable for damages suffered by the Buyer as a consequence of loss of or reduced production, resulting from defects in workmanship covered by this Warranty.

3 CE MARKING / DATA PLATE

The CE marking attests that the equipment complies with the essential safety and health requirements provided for in the European Directives referred to in the CE Declaration of Conformity.

The CE marking consists of a silver-colored polyester adhesive label, printed in black, with the following dimensions: L=50 mm - H=70 mm (**FIG. 1**).

The label is fixed on a side of each device. The following information is written legibly and indelibly on the data plate (some data may be omitted or partially indicated):

- Logo
- Model
- Option
- Serial nr.
- Input
- Output Load
- IP
- CE marking attesting that the device complies with the essential safety and health requirements of the European Directives

TDE MACNO	
MODEL	C: 000407
5D0B007X3TB11B3X0	
OPTION	<input type="checkbox"/> CANBUS <input type="checkbox"/> ENDAT-BISS <input type="checkbox"/> R.F.INT+FILTRO
S/N	1005 12345
INPUT	AC 380V -15% / 460V +10% 9A 50/60Hz 3 PHASE
OUTPUT	AC 0/460 6,8A n / 13,6A pk
LOAD	AC BRUSHLESS MOTOR
IP	IP20 CE
made in Italy	

FIG. 1 (CE Marking and data plate)

4 GENERAL INFORMATION

4.1 IMPORTANCE OF THIS MANUAL



PRIOR TO USING THE DEVICE HEREIN, AUTHORIZED OPERATORS MUST THOROUGHLY READ AND UNDERSTAND THIS ENTIRE MANUAL.

This installation technical manual has been drawn up to ensure that the subjects dealt with in it are easily and correctly understood by the operators authorized to use the device referred to herein and to carry out the relevant maintenance.

If, despite the care taken by the manufacturer in drawing up this manual, the above operators have any difficulties in understanding its contents, they should immediately ask for proper explanations and additional information from the manufacturer, to avoid wrong personal interpretations that might jeopardize safety.

Before using the device referred to herein, authorized operators must thoroughly read and understand this technical manual on "Installation Instructions" and strictly follow all the instructions and norms contained herein, so as to guarantee their own personal safety as well as that of others and obtain the best possible performance from the drive, while ensuring top efficiency and a long service life of all of its components. This manual must be readily available to all authorized operators and must always be kept in good condition near the device.



THIS MANUAL MUST BE AVAILABLE TO AUTHORIZED OPERATORS AT ALL TIMES AND MUST BE KEPT IN GOOD CONDITION NEAR THE DEVICE

THE MANUFACTURER HEREBY DISCLAIMS ALL LIABILITY FOR INJURIES OR DAMAGE THAT COULD BE CAUSED TO PERSONS, ANIMALS OR PROPERTY DUE TO FAILURE TO FOLLOW THE INSTRUCTIONS AND WARNINGS IN THIS MANUAL.



THIS MANUAL MUST BE GIVEN TO THE END USER TOGETHER WITH THE DEVICE, SHOULD THE DEVICE BE RESOLD OR TRANSFERRED TO ANOTHER USER.

THIS MANUAL REFLECTS THE STATE-OF-THE-ART TECHNOLOGY AT THE TIME OF SALE OF THE DEVICE AND CANNOT BE CONSIDERED INADEQUATE JUST BECAUSE UPDATED AT A LATER TIME, BASED ON NEW EXPERIENCE.



IF THE MANUAL IS LOST OR DAMAGED, REQUEST A COPY FROM THE MANUFACTURER, QUOTING THE DEVICE IDENTIFICATION DATA (CE MARKING / DATA PLATE) AND REVISION.

4.2 CONSULTATION NOTES

THE GENERAL DANGER SIGN AND THE TEXT IN BLOCK CAPITALS INSIDE A BOX DRAW THE OPERATOR'S ATTENTION TO THE WARNINGS CONTAINED IN THIS MANUAL.



N.B. (Nota Bene): Text in block capitals within boxes.

Bold type: Highlights important phrases in the text.

Italics: Used for captions of figures and tables.

4.2.1 Addressees of this Manual (Authorized Operators)

This technical manual is addressed solely to operators authorized to use the device and carry out its maintenance, according to the specific technical and professional skills required for each type of task.

The symbols shown below appear at the beginning of each section and/or paragraph, in order to indicate the type of operator concerned with the subject dealt with therein.

AUTHORIZED OPERATORS MAY ONLY CARRY OUT TASKS WITHIN THEIR OWN SPECIFIC COMPETENCE.

PRIOR TO PERFORMING ANY WORK ON THE DEVICE, AUTHORIZED OPERATORS MUST ENSURE THAT THEIR OWN PSYCHOLOGICAL AND PHYSICAL CONDITIONS ARE SUCH AS TO ENSURE OBSERVANCE OF SAFETY PROCEDURES AT ALL TIMES.



OPERATOR IN-CHARGE (TESTER)

Qualified technician (suitable person possessing the technical and vocational skills required by the regulations in force) who is entitled to install and use the device, including in the presence of electrical current and with the protections disabled (with the prior permission of the person in charge of safety) in compliance with the instructions contained in this manual or in any other special document provided by the manufacturer only

OPERATOR AUTHORIZED TO HANDLE THE DEVICE

Trained, skilled operator, aged 18 and up, complying with the laws in force in the country of use.

MANUAL HANDLING OF THE DEVICE MUST BE CARRIED OUT IN COMPLIANCE WITH THE REGULATIONS ON "MANUAL HANDLING OF LOADS" IN ORDER TO AVOID UNFAVOURABLE ERGONOMIC CONDITIONS THAT INVOLVE RISKS OF BACK OR LUMBAR INJURY.



COMPANY SAFETY MANAGER

Qualified technician designated by the Customer, possessing the technical and vocational skills required by the regulations in force on health and safety at the work place.

MANUFACTURER'S TECHNICIAN

Qualified technician provided by the manufacturer and/or by an authorized dealer, in order to carry out the requested technical assistance, routine and special maintenance tasks, or any tasks not indicated in this manual, which require in-depth knowledge of the device.

4.2.2 “Device Off” Status

Always disconnect the device from the power source before performing any maintenance or adjustment.

The drive shall be deemed to be off when at least one of the following conditions is met:

- the fuses connected in series with the power supply have been removed
- the main switch is disconnected at all poles
- no power is supplied

In addition to the above, allow at least 8 minutes in order to make sure that all power inside live components is fully discharged, as indicated on the adhesive label affixed to the **MiniOPD EXP** (s. FIG. 2).

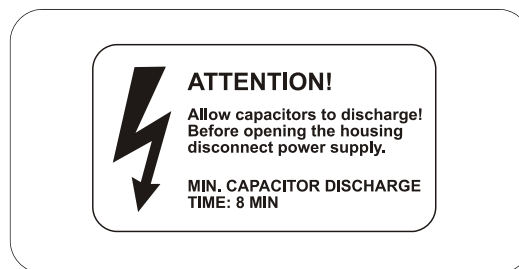

FIG. 2 (Warning label)

4.3 ABBREVIATIONS

Some of the abbreviations appearing this manual are listed in **TAB. 1**.

ca.	Approx.	min	Minutes
Sec.	Section	N.	Number
PPE	Personal Protective Equipment	pag.	Page
RH	Right-Hand	par.	Paragraph
h	Hours	Pos.	Position
EN	European Norm (Standard)	REF.	Reference
Ex.	Example	s	Seconds
FIG.	Figure-Figures	SX	Left-Hand
max.	Maximum	TAB.	Table
min.	Minimum	s.	See

TAB. 1 (Abbreviations)

4.4 ALL RIGHTS RESERVED

All rights on this "Installation Instructions" manual shall remain the property of the Manufacturer. All information contained herein (texts, drawings, diagrams, etcetera) is reserved. No part of this manual may be reproduced or disseminated (whether in full or in part) by any reproduction means (including photocopying, microfilming etc.) without the prior written permission of the Manufacturer.

All trademarks referenced herein are the property of their respective owners.

5 TECHNICAL DESCRIPTION

5.1 NAME OF THE DEVICE

The device referred to herein is called:

MiniOPD EXP

5.2 OPEN DRIVE EXP CODE

Below is a description of the **MiniOPD EXP** code, explaining the meaning of each single letter appearing in the “Type” field of the CE marking/data plate (**s. par. 3**).

5	Level									
D 0	MiniOPD EXP									
	Type	V = Field oriented control + V/f B = Brushless / Brushless sensorless								
	Size	<table border="0"> <tr> <td>002= 2,3A (0,4 kW-220V)</td> <td>002= 2,3A (0,75 kW-400V)</td> </tr> <tr> <td>005= 5,6A (1,1 kW-220V)</td> <td>004= 3,8A (1,5 kW-400V)</td> </tr> <tr> <td>008= 8,4A (2,2 kW-220V)</td> <td>007= 6,8A (3 kW-400V)</td> </tr> <tr> <td>010= 10A (3 kW-220V)</td> <td></td> </tr> </table>	002 = 2,3A (0,4 kW-220V)	002 = 2,3A (0,75 kW-400V)	005 = 5,6A (1,1 kW-220V)	004 = 3,8A (1,5 kW-400V)	008 = 8,4A (2,2 kW-220V)	007 = 6,8A (3 kW-400V)	010 = 10A (3 kW-220V)	
002 = 2,3A (0,4 kW-220V)	002 = 2,3A (0,75 kW-400V)									
005 = 5,6A (1,1 kW-220V)	004 = 3,8A (1,5 kW-400V)									
008 = 8,4A (2,2 kW-220V)	007 = 6,8A (3 kW-400V)									
010 = 10A (3 kW-220V)										
X	Overload	X = Standard (5 kHz PWM)								
	Main supply	2V = 220V 1Ph / 3 Ph 3T = 400V 3Ph								
	Drive	A = Power supply IGBT 24V / Drive 24V B = Autofeed power supply IGBT / Drive 380V (autofeed)								
	Brake	1 = Yes, with internal brake resistor								
	Filter (1)	0 = No 1 = Yes								
	Speed sensor	<table border="0"> <tr> <td>0= No Feedback (2)</td> <td>D= Sin\Cos incremental\ absolute</td> </tr> <tr> <td>A= TTL Encoder+Hall sensor encoder high frequency</td> <td>E= Endat 1317/1329/1313/1325-BISS AD361219(3)</td> </tr> <tr> <td>B=Resolver</td> <td>G = TTL encoder + hall sensor encoder standard</td> </tr> </table>	0 = No Feedback (2)	D = Sin\Cos incremental\ absolute	A = TTL Encoder+Hall sensor encoder high frequency	E = Endat 1317/1329/1313/1325-BISS AD361219(3)	B =Resolver	G = TTL encoder + hall sensor encoder standard		
0 = No Feedback (2)	D = Sin\Cos incremental\ absolute									
A = TTL Encoder+Hall sensor encoder high frequency	E = Endat 1317/1329/1313/1325-BISS AD361219(3)									
B =Resolver	G = TTL encoder + hall sensor encoder standard									
3	Fieldbus	3 = Canbus								
	I/O	0 = No X = Remotable keypad								
0	Variant	0 =Standard								
V	Customer	V = TDE Standard version (<i>a different letter match a specific customization</i>)								

- (1) For the model 2-30 the filter is never present
- (2) Without feedback option board the serial line and CAN bus are not optoisolated
- (3) 1325-BISS only for brushless type

5.3 COMPONENT NAMES AND SIZES

FIG. 3A - 3B show the main components that make up an MiniOPD EXP with the relevant names and overall sizes.

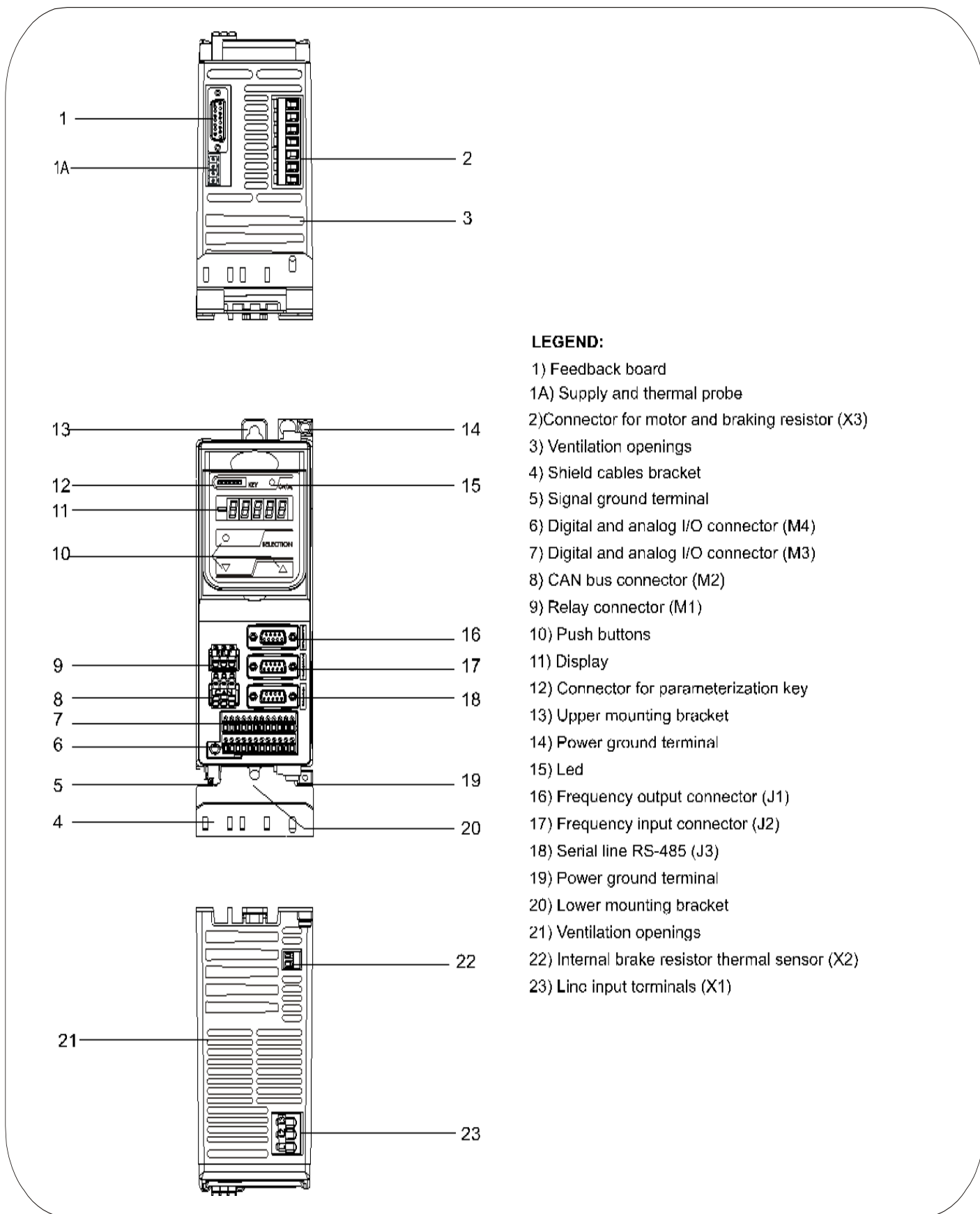

LEGEND:

- 1) Feedback board
- 1A) Supply and thermal probe
- 2) Connector for motor and braking resistor (X3)
- 3) Ventilation openings
- 4) Shield cables bracket
- 5) Signal ground terminal
- 6) Digital and analog I/O connector (M4)
- 7) Digital and analog I/O connector (M3)
- 8) CAN bus connector (M2)
- 9) Relay connector (M1)
- 10) Push buttons
- 11) Display
- 12) Connector for parameterization key
- 13) Upper mounting bracket
- 14) Power ground terminal
- 15) Led
- 16) Frequency output connector (J1)
- 17) Frequency input connector (J2)
- 18) Serial line RS-485 (J3)
- 19) Power ground terminal
- 20) Lower mounting bracket
- 21) Ventilation openings
- 22) Internal brake resistor thermal sensor (X2)
- 23) Line input terminals (X1)

FIG. 3A (Component names)

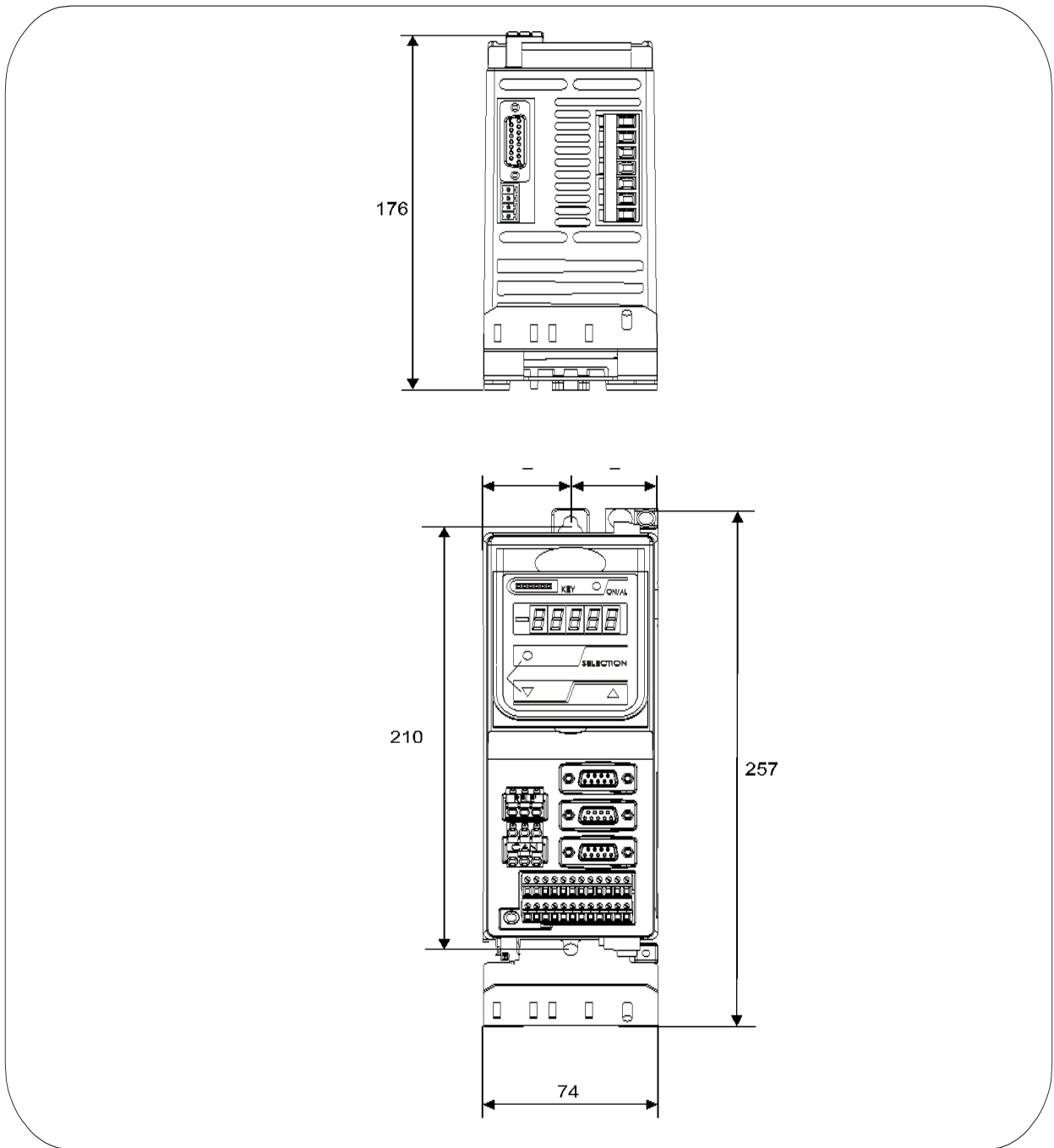

FIG. 3B (Sizes)

Length (mm)	74
Height (mm)	257
Depth (mm)	176
Fixing screws	M5
Weight (kg)	2

TAB 2 (Sizes and weight)

5.4 TECHNICAL DATA

Mod. MiniOPD EXP		2-04	2-11	2-22	2-30	4-08	4-15	4-30	
Power supply									
Input Voltage (Vi)	Vrms	110V -10% ÷ 240+10%, 1-Ph / 3Ph (Rated voltage: 230Vac)				230V -10% ÷ 460+10%, 3Ph (Rated voltage: 400Vac)			
Frequency	Hz	50 ÷ 60Hz ±5%							
D.C. Voltage	VDC	310 ±10%				560 ±10%			
Input current at rated power (without inductance)	1 Ph	Arms	5	11,5	17	20	--	--	--
	3 Ph		3	7,5	11	13	3	5	9
Input current at rated power (With inductance ΔV=3%)	Arms	4	8,5	12,5	15	--	--	--	
Output									
Output Voltage	Vrms	Vout max. = Vi x 0,94							
Output Frequency	Hz	0 ÷ 1100							
(1) C56 = 0		Overload 120% for 30 s (Arms)							
Rated Output Current In (2)[A]		2,7	6,7	9,9	11,8	2,7	4,5	8	
Transitory Overload 30 s f>2,5Hz [A]		3,2	8	11,9	14,2	3,2	5,4	9,6	
C56 = 1		Overload 150% for 30 s							
Rated Output Current In (2)[A]		2,4	5,9	8,8	10,5	2,4	4	7,1	
Transitory Overload 30 s f>2,5Hz[A]		3,6	8,9	13,2	15,8	3,6	6	10,7	
C56 = 2		Overload 200% for 30 s (Arms)							
Rated Output Current In (2)[A]		1,9	4,8	7,2	8,5	1,9	3,2	5,8	
Transitory Overload 30 s f>2,5Hz[A]		3,9	9,6	14,3	17,1	3,9	6,4	11,6	
C56 = 3		Overload 200% for 3 s and 155% for 30 s (Arms)							
Rated Output Current In (2)[A]		2,3	5,6	8,4	10	2,3	3,8	6,8	
Transitory Overload 1 30 s f>2,5Hz[A]		4,6	11,2	16,8	20	4,6	7,6	13,6	
Transitory Overload 2 30 s f>2,5Hz[A]		3,6	8,7	13	15,5	3,6	5,9	10,5	

TAB. 3A (Technical data)

Braking resistor									
Mod. OPEN DRIVE EXP			2-04	2-11	2-22	2-30	4-08	4-15	4-30
Internal	Resistance	Ω	41			110			
	continuous average power	W	40			40			
External	Resistance (minimum)	Ω	30			120			
	Maximum power	W	4000			4000			



ATTENTION: If the value of the external resistance is different to the internal resistance, the thermal image parameters must be correct

TAB. 3B (Technical data)

Mod. MiniOPD EXP		2-04	2-11	2-22	2-30	4-08	4-15	4-30
Modulation		Space Vector PWM						
PWM Frequency		3÷12kHz (default = 5kHz)						
Reference Signals		Up to Nr.2 programmable analog references						
		1 frequency inputs (A / A - B / B) or FREQ. AND UP/DOWN						
Working Temperature (3)	°C	0 ÷ 40						
Storage Temperature	°C	-10 ÷ +60						
Altitude (4)	m	1000						
Vibrations	g	0,2						
Humidity	%	condensation not permitted						
Protection Degree		IP 20						

- (1) Connection C56 determines the type of overload.
 (2) Rated current for continuous duty at 5kHz PWM. **FIG.4** shows the automatic derating pattern as a function of PWM frequency (P101) and AC supply (P87).
 (3) Allowable ambient temperature up to 45 °C. In this case, derate current to 88% I_n.
 (4) At altitudes above 1000 m above sea level, derate current by 1% each 100 m.

TAB. 3C (Technical data)

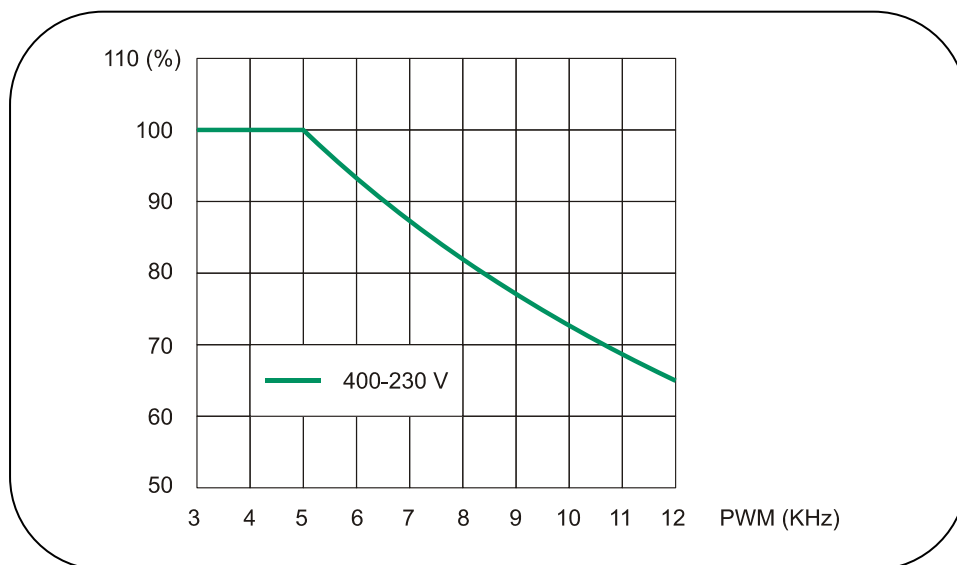

FIG. 4 (Converter derating)

5.5 INTENDED USE

This MiniOPD EXP has been designed and manufactured for the following intended use:

FIELD OF USE	Electric and electronic industry for motion control.
PLACE OF USE	<p>Closed, covered, sufficiently lit environment with temperature and humidity values within the ranges indicated in TAB. 3C and complying with the regulations on safety and health at the work place in force in the Country where the drive is used. MiniOPD EXP must be installed on a wall capable of ensuring stability in relation to its overall dimensions (see FIG. 3B) and weight (see TAB. 2); observe minimum clearances shown in FIG. 5.</p> <p>N.B.: PRESENCE OF WATER OR HUMIDITY ABOVE 90% IN THE PLACE OF USE OF THE MINIOPD EXP IS ABSOLUTELY FORBIDDEN, AS IT MAY ENHANCE OR INCREASE THE RISK OF ACCIDENTAL ELECTRIC SHOCK AND/OR DAMAGE TO THE DRIVE ITSELF.</p>
OPERATOR IN CHARGE (SUITABLE PERSON)	One single authorized operator complying with the requirements described in par. 4.2.1 .

5.6 OPERATIONAL STEPS

- 1) Electric connections (s. par. 7.2);
- 2) Powering up MiniOPD EXP (s. par. 7.2.2);
- 3) Using MiniOPD EXP;
- 4) Switching MiniOPD EXP by disconnecting the power supply and waiting long enough for all power in the components to be fully discharged

5.7 USE LIMITATIONS

The MiniOPD EXP referred to herein has been designed and manufactured solely for the intended use described in par. 5.5; consequently, any other use or application is strictly forbidden, in order to guarantee the operator's safety as well as the most efficient operation at all times.



IT IS STRICTLY FORBIDDEN TO OPERATE THE MINIOPD EXP IN ENVIRONMENTS WITH POTENTIALLY EXPLOSIVE ATMOSPHERE AND/OR IN THE PRESENCE OF COMBUSTIBLE DUST (SUCH AS WOOD DUST, FLOUR, SUGAR, GRAIN AND THE LIKE).



USE LIMITATIONS: IT IS STRICTLY FORBIDDEN TO EMPLOY AND USE THE MINIOPD EXP FOR IMPROPER USES, OTHER THAN ITS INTENDED USE (PAR. 5.5). IT IS STRICTLY FORBIDDEN TO OBSTRUCT AIR INTAKE OPENINGS (FIG.3A).

USE LIMITATIONS: IT IS STRICTLY FORBIDDEN TO OPERATE THE MINIOPD EXP IN ENVIRONMENTS SUBJECT TO HEAVY VIBRATIONS; IF IT IS INSTALLED ON A MOBILE EQUIPMENT, USE APPROPRIATE VIBRATION DAMPING SYSTEMS.

USE LIMITATIONS: IT IS STRICTLY FORBIDDEN TO OPERATE THE MINIOPD EXP IN A DUSTY AND POORLY VENTILATED ENVIRONMENT. AVOID AMBIENT CONDITIONS WHERE THE DRIVE IS EXPOSED TO AGGRESSIVE GASES, AS THE PRESENCE OF ABRASIVE POWDERS, VAPOURS, OIL MIST OR BRACKISH AIR MIGHT AFFECT THE LIFE OF THE DRIVE



THE PRESENCE OF WATER IN THE PLACE OF USE OF THE MINIOPD EXP IS STRICTLY FORBIDDEN, AS IT MAY ENHANCE OR INCREASE THE RISK OF ACCIDENTAL ELECTRIC SHOCK OR ELECTROCUTION.

6 TRANSPORTATION AND HANDLING

6.1 TRANSPORTATION

MiniOPD EXP is shipped to the Customer's location via a carrier authorized by the customer or by the manufacturer, depending on the terms of the sales contract.

6.2 PACKAGING

The type of packaging varies depending on the model and form of shipping.

CHECK THAT THE PACKAGING HAS NOT BEEN DAMAGED DURING TRANSPORTATION. NOTE ANY DAMAGE ON THE TRANSPORT DOCUMENT (D.D.T.) AND PLACE YOUR SIGNATURE FOR "CONDITIONAL ACCEPTANCE" ON SAID DOCUMENT



6.3 LIFTING AND HANDLING THE PACKAGING

THE PACKAGING THAT CONTAINS THE OPEN DRIVE EXP MUST BE LIFTED WITH UTMOST CARE.



6.4 UNPACKING

When unpacking the drive, use suitable tools (e.g. a cutter) and protection equipment (e.g. gloves), as required.

IT IS RECOMMENDED THAT THE PACKAGING MATERIAL BE DISPOSED OF ACCORDING TO THE TYPE OF MATERIAL, IN COMPLIANCE WITH THE LEGISLATION IN FORCE IN THE USER'S COUNTRY.



6.5 STORAGE

If **MiniOPD EXP** needs to be stored for a long time, place it in a safe location, with suitable temperature and humidity conditions and protect it against dust.

6.5.1 Environmental Storage Conditions

Temperature	°C	-10 ÷ 60
Humidity	%	5 ÷ 95
Condensation		NO

TAB.4 (Environmental storage conditions)

6.5.2 Recovery Procedure After Storage

MiniOPD EXP Activation cannot be used immediately after a storage period. In order to avoid faults during activation, the following recovery procedure must be adopted.

• PHASE 1

MiniOPD EXP recovery conditions		
Temperature	°C	0 ÷ 35
Humidity	%	5 ÷ 75
Condensation		NO
Atmospheric pressure	KPa	86 ÷ 106
Recovery time ⁽¹⁾	h	1
⁽¹⁾ After this recovery time there must be no trace of condensation, both inside and outside activation (well ventilated area).		

TAB. 5 (Recovery after storage)

• PHASE 2

For storage periods longer than one year, the regeneration of power bus and supply circuit board electronic capacitors is obligatory. Power the MiniOPD EXP through line input terminals for 30 min ÷ 2 h, without giving run consent.

Once the regeneration process is completed, the MiniOPD EXP can work normally



TEMPERATURE VARIATIONS CAN CAUSE CONDENSATION TO FORM IN THE APPARATUS, WHICH IS NOT PERMITTED DURING OPERATION.

MAKE SURE THERE IS NO CONDENSATION IN THE APPARATUS TO BE POWERED

7 INSTALLATION

7.1 INSTALLATION

Install **MiniOPD EXP** as instructed below:

- 1) Position the **MiniOPD EXP** observing the minimum clearances around it (**see FIG. 5**);
- 2) Secure the **MiniOPD EXP** to the wall by means of screws, according to the dimensions shown in **FIG. 3B e TAB. 2**.

THE MINIOPD EXP MUST BE INSTALLED BY AUTHORIZED OPERATORS ONLY (S. PAR. 4.2.1).

WHEN INSTALLING THE MINIOPD EXP, BE ABSOLUTELY SURE THAT THE ELECTRICAL PANEL TO WHICH THE DRIVE IS GOING TO BE CONNECTED IS POWERED OFF (DISCONNECTED).

ANY OPERATION INSIDE THE MINIOPD EXP MUST BE PERFORMED WITH THE POWER OFF; ALWAYS WAIT AT LEAST 8 MIN. BEFORE GAINING ACCESS TO THE INSIDE OF THE DRIVE (SEE FIG. 2).

THE MINIOPD EXP MUST BE INSTALLED VERTICALLY, THIS BEING THE ONLY POSITION THAT WILL NOT EFFECT HEAT CONVECTION, WHICH CAN RESULT IN DAMAGE. IF YOU CANNOT INSTALL THE DRIVE IN VERTICAL POSITION, CONTACT WITH TDE'S TECHNICIANS, WHO SHALL EVALUATE CASE BY CASE.

GOOD ACCESSIBILITY TO ALL CONTROL DEVICES MUST BE ENSURED.

IF SEVERAL MINIOPD DRIVES ARE TO BE INSTALLED, INSTALL THEM AS ILLUSTRATED IN FIG. 5 TO ENSURE PROPER VENTILATION AND PREVENT THE COOLING AIR FLOW FROM ONE DRIVE FROM INTERFERING WITH THE OTHER DRIVE.



If the drive is installed in a confined space such as a cabinet, take care to ensure that the temperature inside such space does not exceed the maximum allowed ambient temperature for the drive.

If needed, provide sufficient air ventilation to remove the heat generated by the converter and by other components.

Any other equipment should be installed at a sufficient distance from the drive, in order to prevent any metal residues from drilling operations or from electric cables from falling into the drive.

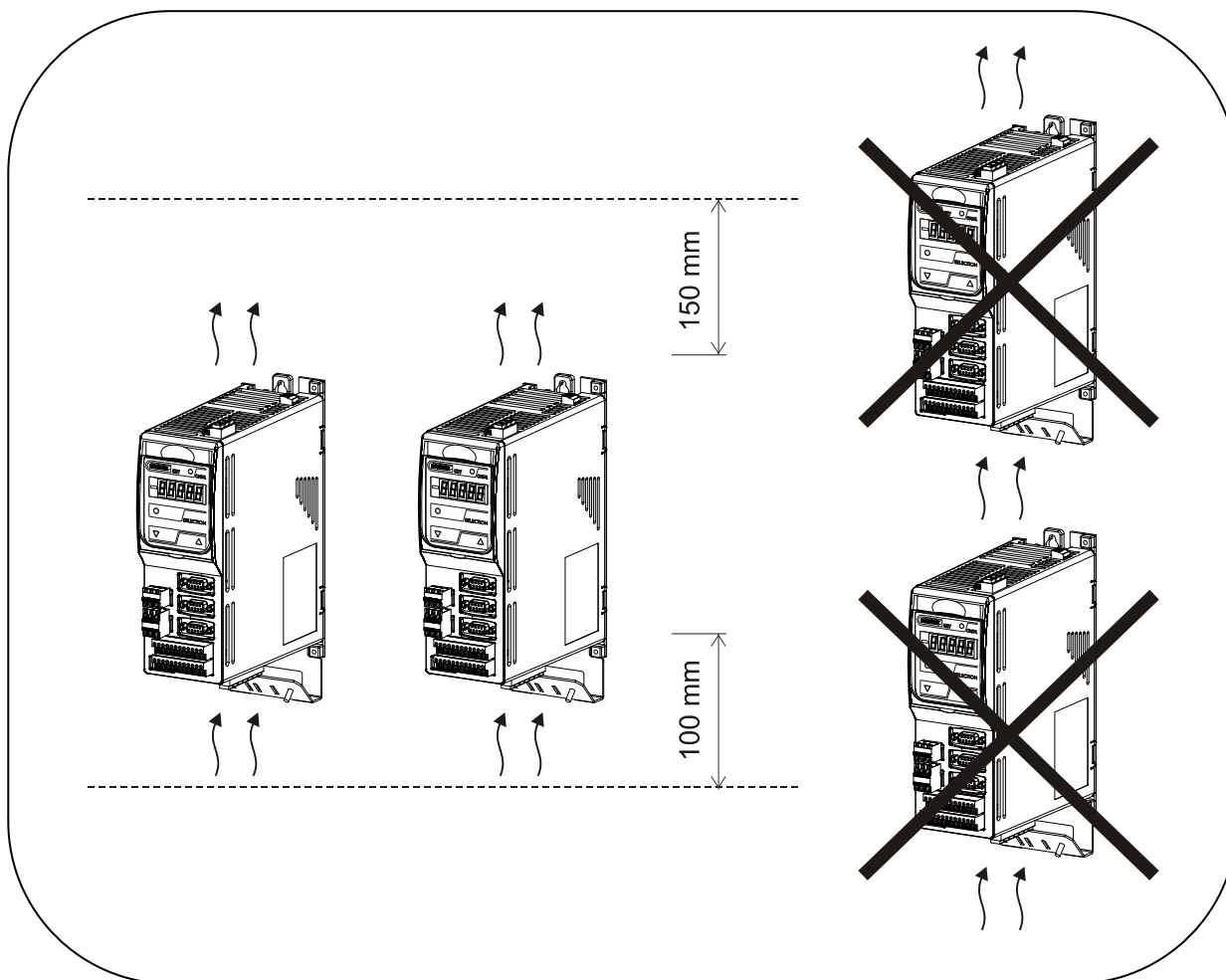

FIG. 5 (Installation)

Mod.	Watt
2-04	40
2-11	70
2-22	113
2-30	145
4-08	57
4-15	85
4-30	145

TAB. 6 (Losses at rated current, nominal voltage, PWM= 5 KHz)

7.1.1 Feedback Board Replacement

The figure show how to replace the feedback board

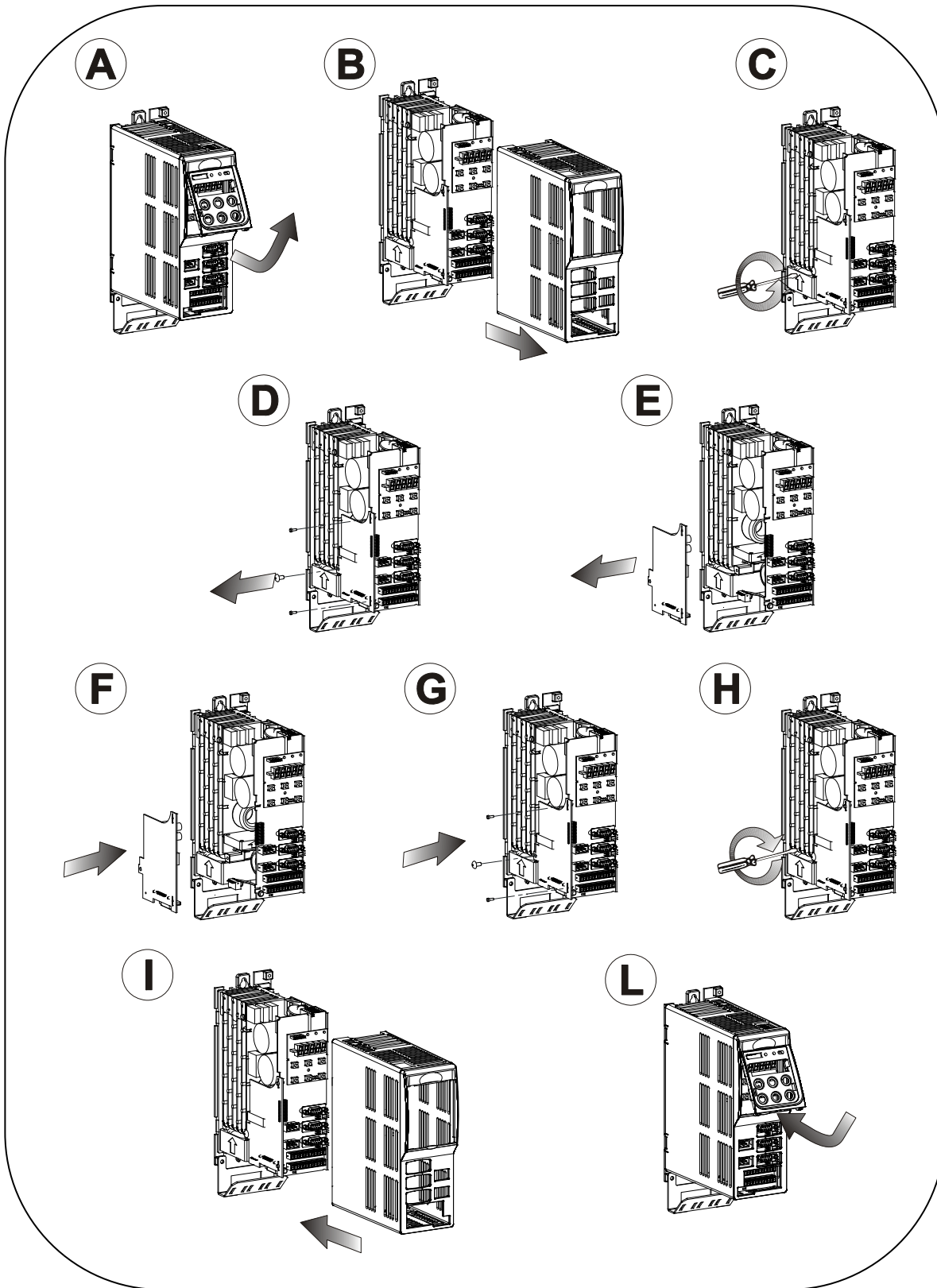

FIG. 6 (Feedback board replacement)

7.2 ELECTRICAL CONNECTIONS

ALL THE STEPS DESCRIBED BELOW ARE NEEDED TO PREPARE THE ELECTRICAL CONNECTION OF THE MINIOPD EXP.

THE POWER MAINS TO WHICH THE MINIOPD EXP IS CONNECTED MUST MEET THE TECHNICAL SPECIFICATIONS IN TAB. 3A/3B/3C (PAR. 5.4) AND FULFILL THE REQUIREMENTS OF THE LAWS IN FORCE IN THE COUNTRY OF USE.

ANY TYPE OF ELECTRICAL MATERIAL (CABLES, SOCKETS, PLUGS AND SO ON...) USED TO MAKE THE CONNECTIONS MUST BE SUITABLE FOR USE, MUST BEAR THE "CE" MARKING IF IT IS SUBJECT TO THE LOW VOLTAGE DIRECTIVE 2006/95/CE AND MUST COMPLY WITH THE REQUIREMENTS OF THE LAWS IN FORCE IN THE COUNTRY WHERE THE MINIOPD EXP IS USED.

THE MANUFACTURER DISCLAIMS ALL LIABILITY FOR FAULTS OR MALFUNCTIONS OF THE MINIOPD EXP DUE TO VOLTAGE FLUCTUATIONS BEYOND THE TOLERANCES SPECIFIED BY THE ELECTRICITY DISTRIBUTION AUTHORITY.

FAILURE TO OBSERVE THE ABOVE WARNINGS AND INSTRUCTIONS MAY RESULT IN IRREPARABLE DAMAGE TO THE ELECTRICAL COMPONENTS OF THE MINIOPD EXP AND IN THE FORFEITURE OF THE WARRANTY.

THE MANUFACTURER HEREBY DISCLAIMS ALL LIABILITY FOR INJURIES OR DAMAGE THAT COULD BE CAUSED TO PERSONS, ANIMALS OR PROPERTY AS A RESULT OF WRONG ELECTRICAL CONNECTION OF THE DRIVE AND ITS COMPONENTS.

REFERENCE TO THE CONNECTION DIAGRAMS IN FIG. 7 IS COMPULSORY.



The figure below shows the main connections of the drive.

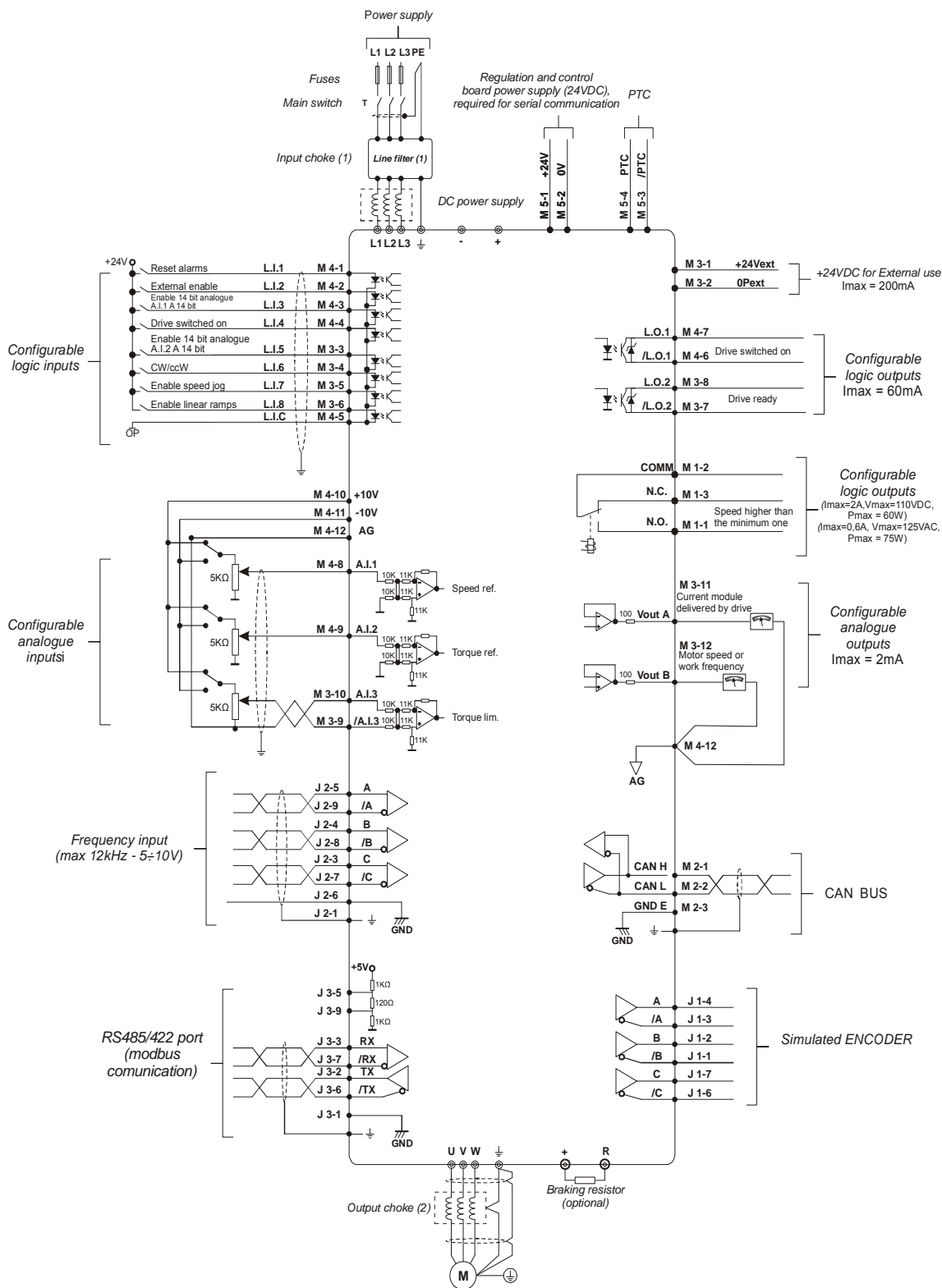

FIG. 7 (Electrical Connections)

- (1) The external filter is necessary for the models that don't have the internal filter
- (2) Only for 15mt or longer connection

7.2.1 Power Stage

The mains voltage applied to terminals **L1, L2, L3** (s. **FIG. 8**) is rectified by the rectifier bridge **DB** and is filtered by capacitor bank **CB**. **V BUS** continuous voltage is modulated by six **IGBTs** that are piloted by the microprocessor-controlled Driver card. **U,V,W** are the motor phases (**PWM** voltage) (**FIG. 8**).

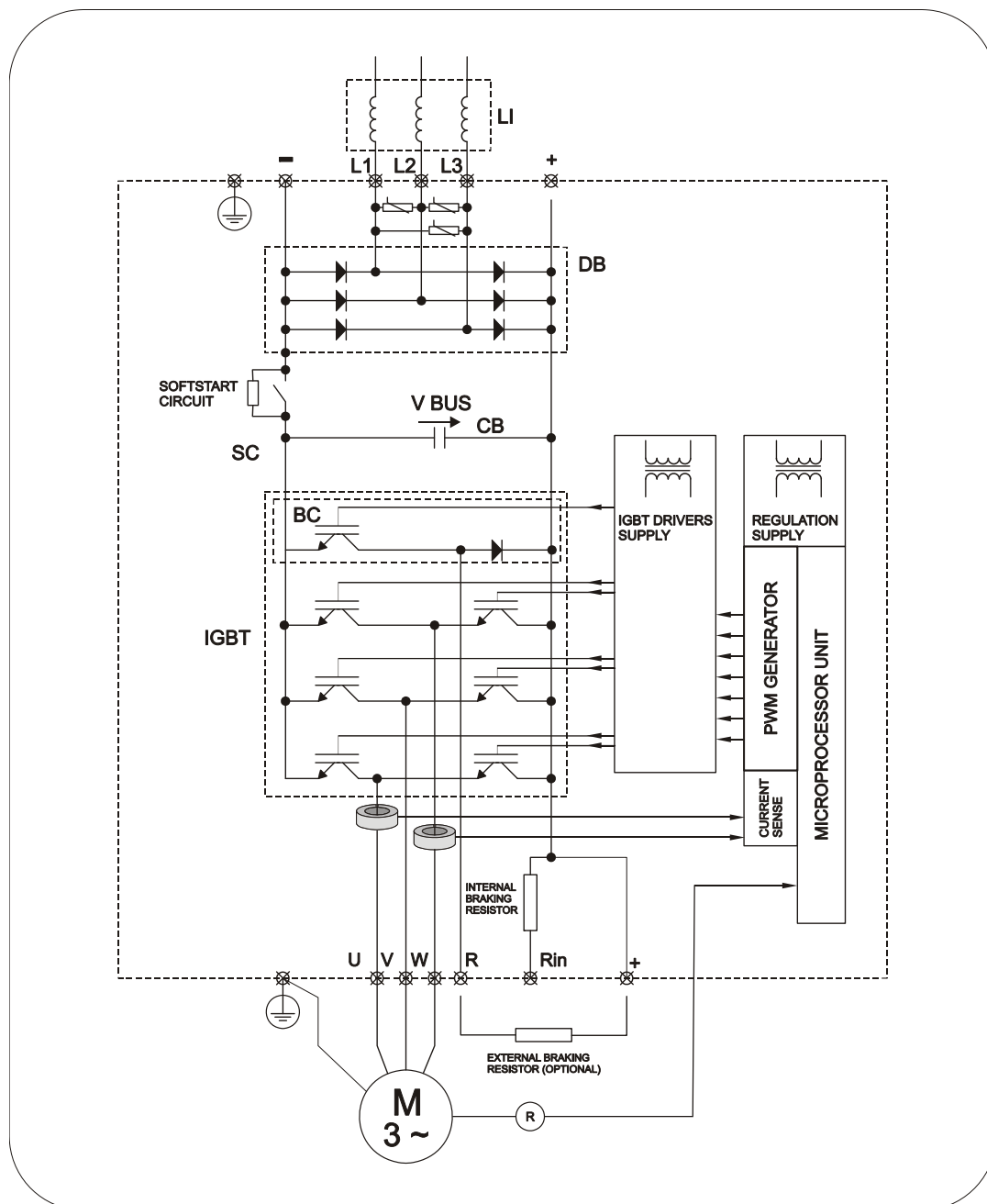

FIG. 8 (Power stage)

7.2.2 Mains Connection

When connecting MiniOPD EXP drives to 3-phase supply mains we recommend using a 3-phase input choke (inductor). In particular cases, the inductance can be omitted. Please, contact TDE Macno technicians.

The 3-phase input choke (**LI**) is used to reduce the current peaks on the diode bridge **DB** and the effective value of the current through the capacitors.

It is also used to reduce interference from the supply line to the MiniOPD EXP and from the drive to the line.

For the size of the input current limiting choke s. **TAB. 18**.

The drive must be wired steadily through appropriately sized cables, both to the three phases, i.e. terminals **L1**, **L2**, **L3**, and to the ground, **PE** stud (s. **TAB. 7**).

NOTE: Models MiniOPD EXP feature a soft-start function built in the drive with both AC and DC power supply.

NOTE: If is necessary supply more MiniOPD EXP with the same line is better connect the drive, without internal filter, to only one line filter (considering the total power) instead of using drives each with its own internal filter, so to reduce the leakage current

7.2.2.1 Using Differential Switches (ELCB)/Residue Current Devices (RCD)

There are three common types of ELBC (Earth Leakage Circuit Breaker) / RCD (Residual Current Device):

AC - identifies the a.c. fault currents

A - identifies the a.c. fault currents and the d.c. pushbuttons (under the condition that the d.c. arrives at zero at least once every half cycle)

B - identifies the a.c. fault currents, the d.c. pushbuttons, and the d.c. filtered fault currents

The AC type must never be used in converters

The A type can only be used in single phase converters

The B type must be used in three phase converters

7.2.3 Pre-Charge (Soft Start)

The **SC** Circuit (Soft start Circuit s. **FIG. 8**) is used to limit the capacitors charge current **CB** (**FIG. 8**) during the power-up phase.

7.2.4 Connecting the Motor

The motor must be connected to terminals **U, V, W (FIG. 10A)** with the ground cable connected to the **PE stud (FIG. 10B)**. Always use cables of appropriate size (**see TAB. 7**).

Connect the motor by means of shielded or armored cables only and ground the shield on the converter side as well as on motor side. If shielded cables cannot be used, the motor cables should be placed in a metallic raceway connected to ground.

TDE MACNO recommends to use an inductance between the drive and the motor.

If the cables are longer than 15 meters the inductance is mandatory

Any short circuit between **U, V, W** will cause the converter to shut down. If the interruption between the motor and the MiniOPD EXP is obtained by means of electromagnetic switches (such as contactors, thermal relays and the like) ensure that the drive is disabled before cutting off the connection between the motor and the converter (the motor current must be null), in order not to damage the contactor.

Mod.		Power Cables (mm ²)	
		Mains (L1, L2, L3) / Motor (U, V, W)	PE Protection Cables (mm ²)
Single phase	2-04	1,5	1,5
	2-11	2,5	2,5
	2-22	4	4
	2-30	6	6
Three phase	2-04	1,5	1,5
	2-11	2,5	2,5
	2-22	4	4
	2-30	4	4
	4-08	1,5	1,5
	4-15	2,5	2,5
	4-30	2,5	2,5

TAB 7 (Power cables)



N.B.: THE BLOCK LEAD TIME FOR THE MiniOPD EXP CAN BE OBTAINED SIMPLY BY ACTING ON THE OPENING DELAY OF ELECTROMECHANICAL COMPONENTS; ANYHOW, A MINIMUM TIME OF 30 MS IS REQUIRED.

7.2.5 Grounding the Drive

The leakage current is the current that the drive discharges towards the ground (earth) connection.

The amount of such current depends on the voltage, the PWM frequency and the parasitic capacity to ground the motor and connection cable. Also the noise filters, if any, are likely to increase the amount of leakage current.

If an RCD (Residual Current Device) is installed, the drive will work without false input as long as:
a type B RCD is being used
the RCD release limit is 300 mA (TT or TN systems)
each RCD powers only one drive
the output cables are shorter than 50 metres (screened) or 100 metres (unscreened)



THE RCDS USED MUST SUPPLY PROTECTION FROM THE DIRECT CURRENT COMPONENTS PRESENT IN THE FAULT CURRENT AND MUST BE SUITABLE FOR SUPPRESSING CURRENT PEAKS QUICKLY. WE RECOMMEND PROTECTING THE DRIVE SEPARATELY USING FUSES, AND OBSERVING THE REGULATIONS OF THE INDIVIDUAL USER COUNTRIES

The leakage current contains significant high-frequency perturbations. For electromagnetic compatibility issues pls. refer to **par. 8.2-** Interference Suppression Measures.



ALWAYS MAKE SURE THAT THE MINIOPD EXP IS DISABLED BEFORE DISCONNECTION FROM THE MOTOR.

THIS DRIVE CANNOT WORK UNLESS THE PROTECTION CONDUCTOR IS STEADILY GROUNDED (EARTHED).

7.2.6 Braking

The **BC** (braking circuit) (**s. FIG. 8**) is used to convert the braking energy into heat by means of the internal resistor or an external resistor (OPTIONAL)

7.2.7 Connection Via Shared Bus

MiniOPD EXP drives can be powered by a common bus by means of a suitable DC supply unit or diode bridge (s. FIG. 9).

The advantages that may stem from this configuration are the energy exchange between connected drives and the increased capacity of the capacitor bank.

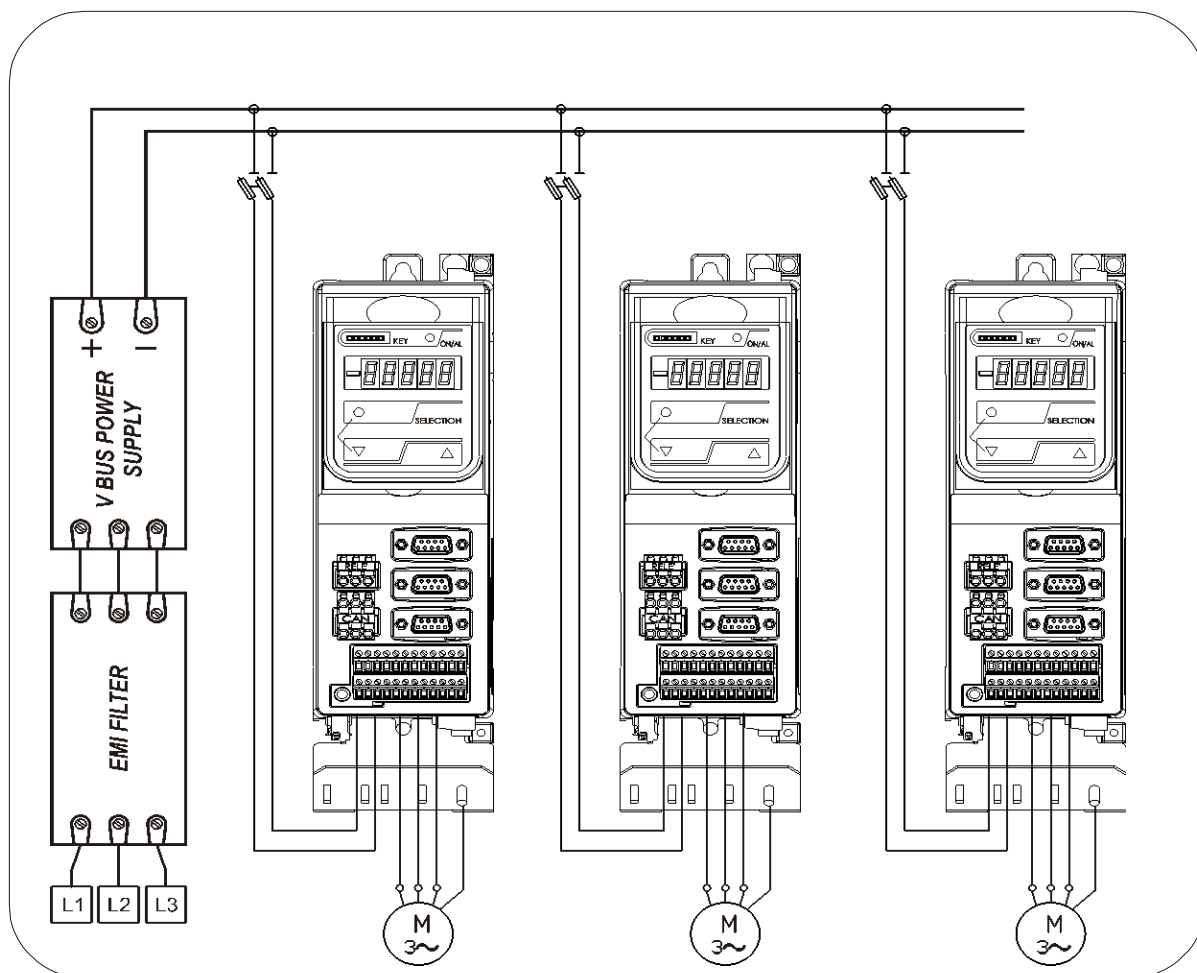

Fig. 9 (Connection via shared bus)

7.2.8 Power Connections Layout

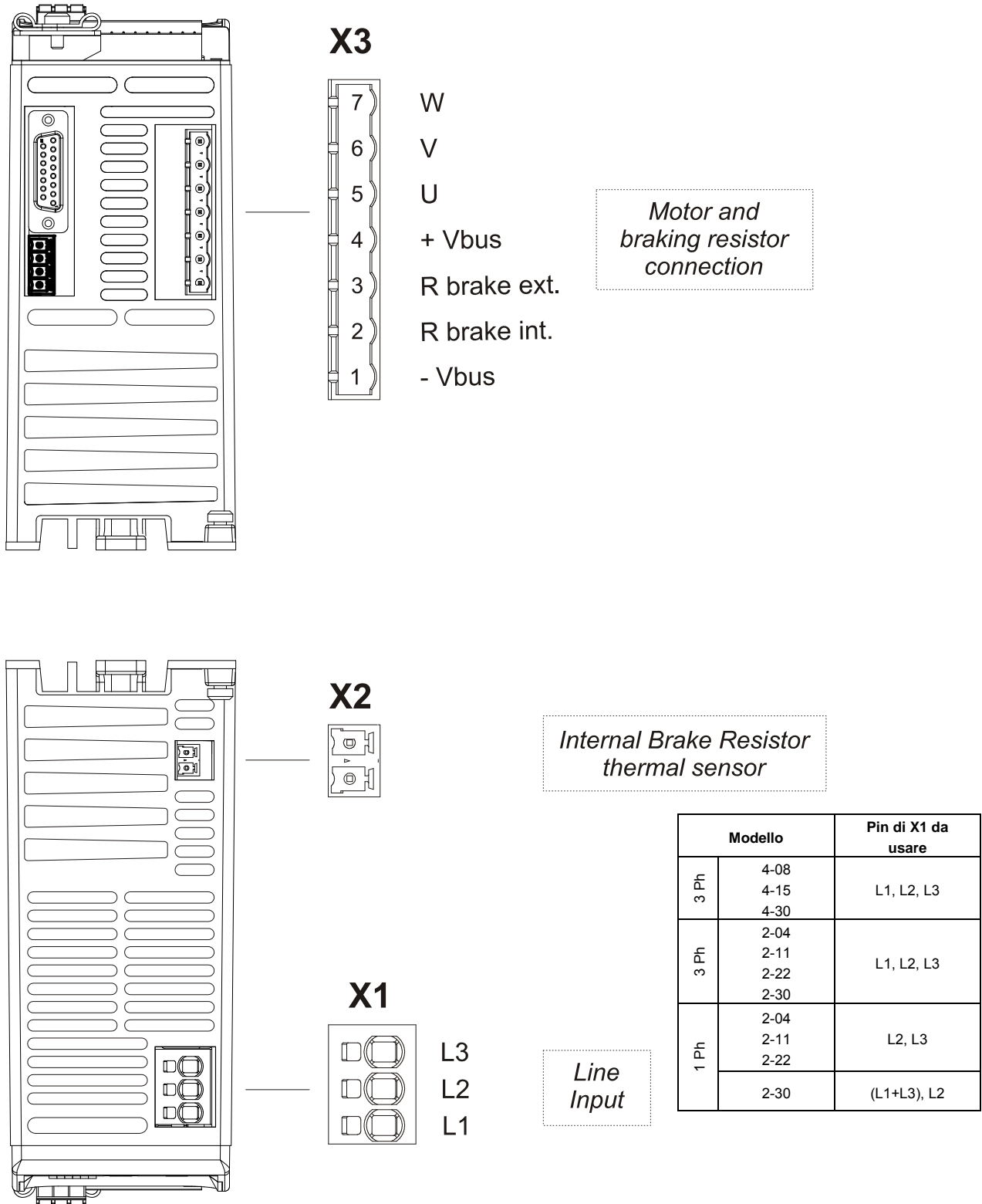

FIG. 10A (Power connections layout)

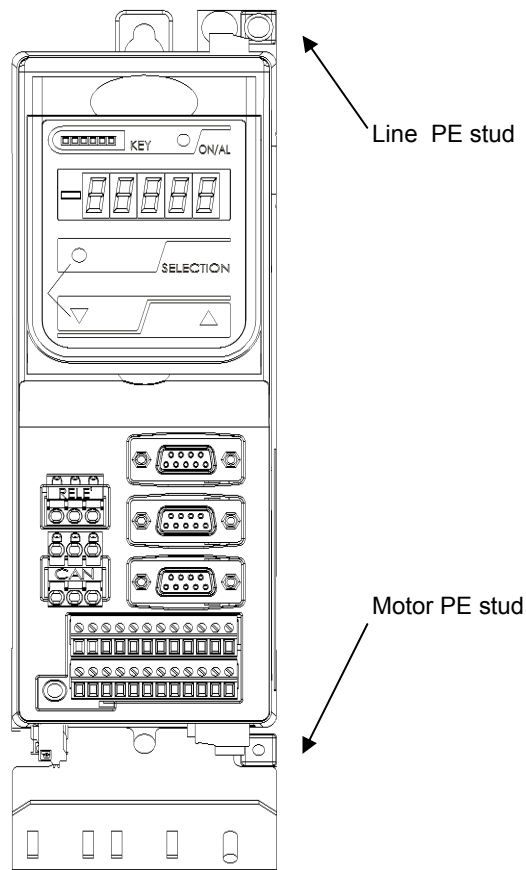

FIG. 10B (Ground connections layout)

For the models 2-22 and 2-30 the supply wires must be plug in the connector using a screwdriver positioned as indicate in the following image

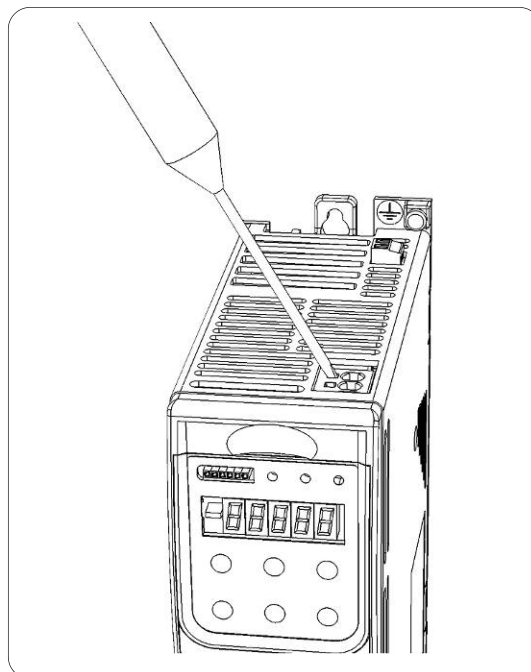

FIG. 11

7.2.8.1 Braking Resistor

MINIOPD	INTERNAL	EXTERNAL
400V	110 Ω	120 Ω (MIN)
	500J (Impulsive) 30 W (CONTIN.)	4 kW (MAX CONTIN.)
230V	41 Ω	30Ω (MIN)
	500J (Impulsive) 30 W (CONTIN.)	4 kW (MAX CONTIN.)

TAB. 8 (Braking resistor)

Connection:

Internal braking resistor: connect R brake int. with R brake ext. (+Vbus disconnected)

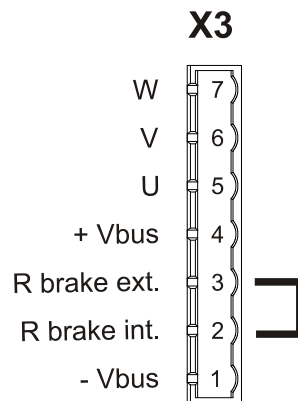

External braking resistor: connect R brake ext. and + Vbus



Warning! R brake int. must be disconnected

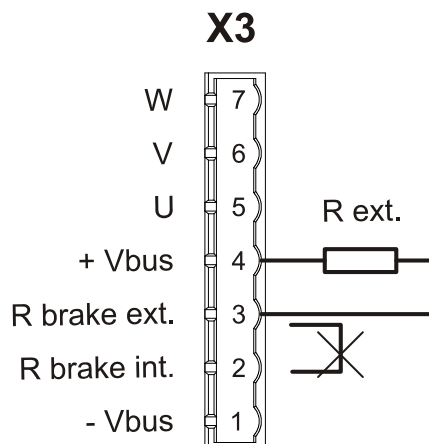

7.2.9 Logic connections

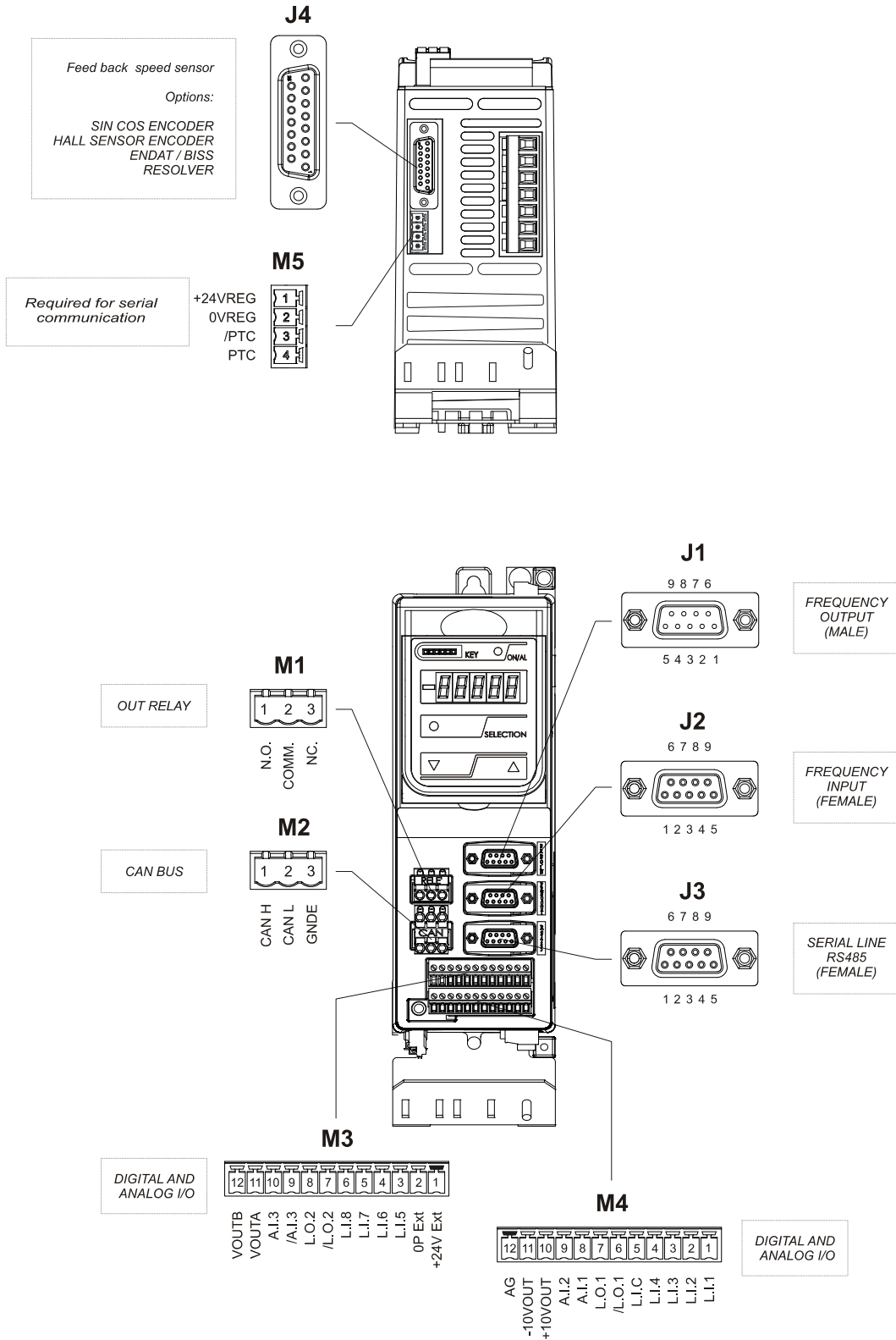
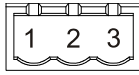

FIG. 12 (Logic connection layout)

7.2.10 Digital and Analog Logic Connections

7.2.10.1 Out Relay

M1		
PIN	FUNCTION	DESCRIPTION
1	N.O.	Normally Open
2	COMM	Common
3	N.C.	Normally Closed

(R load: 2 A max, 110VDC max., 60W MAX)
(R load: 0,6 A max, 125VAC max., 75W MAX)

TAB. 9 (OUT Relay)

7.2.10.2 CAN BUS

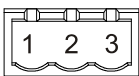
M2		
PIN	FUNCTION	DESCRIPTION
1	CAN H	Can bus
2	CAN L	
3	GND E	

TAB. 10 (CAN BUS)

After removing the plastic cover and the keypad you can access the jumper that allows you to terminate the connection.

If the jumper is closed the signal CAN H and CAN L are connected by a resistance of 120Ω
The jumper is on the right of the CAN connector as indicated in the following image

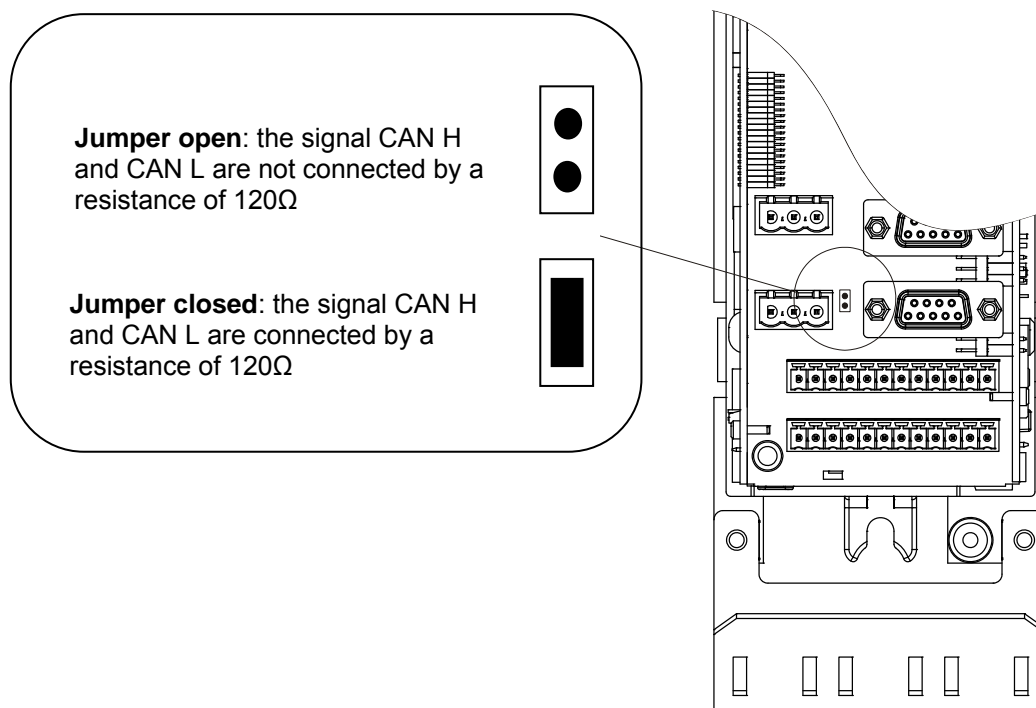

Fig. 13 (CAN bus termination)



The absolute maximum rating for the voltage applied to the transceiver (CANH, CANL) is $-27V \div +40V$. Voltages outside this range can seriously damage the CAN Bus line. Use limiting circuit in case the range cannot be guaranteed (ex. 4V0028). 4V0028 provide also a Jumper that allows terminating the line with the 120Ohm resistor required.

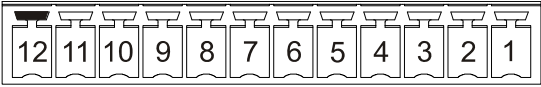

Fig. 13.1 (CAN bus termination with 4V0028)

7.2.10.3 Digital and Analog I/O

M3											
PIN	FUNCTION	DESCRIPTION									
1	+24V Ext	I _{max} : 200mA N.B. This pins provide +24V for External use (ex. I/O)									
2	0P Ext										
3	L.I.5	Configurable Logic Inputs (s. FIG. 14). All inputs are optoisolated from the internal regulation. L.I.C. is the common of inputs L.I.5, L.I.6, L.I.7, L.I.8.									
4	L.I.6										
5	L.I.7										
6	L.I.8										
7	/L.O.2	Configurable Logic Outputs (see FIG. 16). All outputs are optoisolated from the internal regulation. The transistor is conductive when the output is ACTIVE. I _{max} = 60 mA.									
8	L.O.2										
9	/A.I.3	Configurable Analog Inputs (s. FIG. 15). Inputs: +/-10V max. 0.5mA.									
10	A.I.3										
11	VOUTA	Configurable Analog Output (see FIG. 17). Output: ± 10V /2mA.									
12	VOUTB										

TAB. 11 (Digital and analog I/O)

M4											
PIN	FUNCTION	DESCRIPTION									
1	L.I.1	Configurable Logic Inputs (see FIG. 14). All inputs are optoisolated from the internal regulation. L.I.C. is the common of inputs L.I.1, L.I.2, L.I.3, L.I.4.									
2	L.I.2										
3	L.I.3										
4	L.I.4										
5	L.I.C	Logic Inputs Common to be connected to the negative of the input supply									
6	/L.O.1	Configurable Logic Output (see FIG. 16). All outputs are optoisolated from the internal regulation. The transistor is conductive when the output is ACTIVE. I _{max} = 60 mA.									
7	L.O.1										
8	A.I.1	Configurable Analog Inputs (referred to AG).									
9	A.I.2	Inputs: +/-10V max. 0.5mA									
10	+10VOUT	Stabilized supply 10mA maximum (ref. PIN 12).									
11	-10VOUT										
12	AG	0V									

TAB. 12 (Digital and analog I/O)

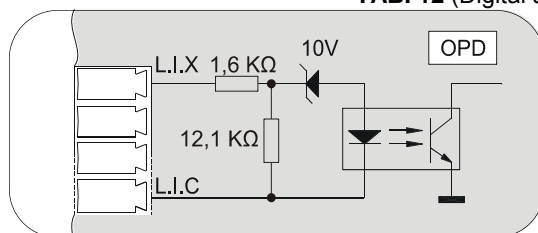

FIG. 14 (Configurable logic inputs)

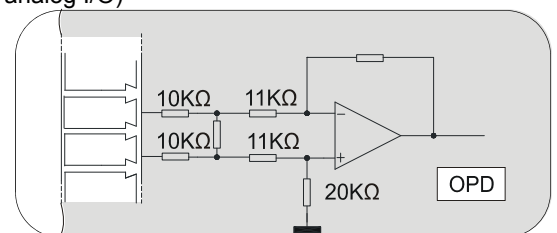

FIG. 15 (Configurable analog input)

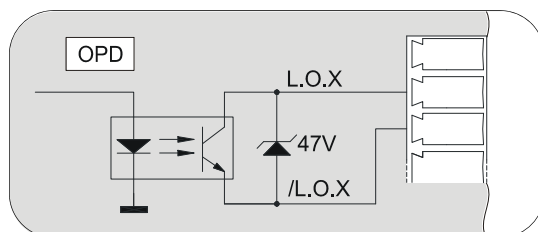

FIG. 16 (Configurable logic output)

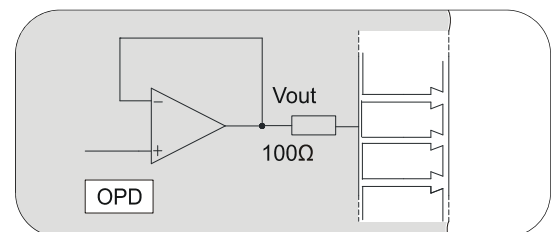
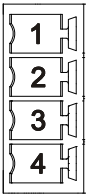

FIG. 17 (Configurable analog output)

7.2.10.4 Supply and Thermal probe

M5	PIN	FUNCTION	DESCRIPTION
	1	+24VREG	+24VDC (+/- 10%) Supply for regulation and control card, required for serial communication. I _{ass} =1,2A
	2	0VREG	
	3	/PTC	Motor thermal probe input (PTC or NTC or KTY84).
	4	PTC	

TAB. 13 (Supply and thermal probe)

7.2.10.5 Frequency Output

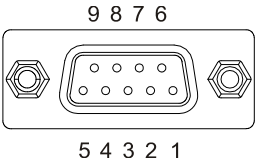
J1 (Male)			
	PIN	FUNCTION	DESCRIPTION
1	CHANNEL /B	Connection for Simulated Encoder	
2	CHANNEL B		
3	CHANNEL /A		
4	CHANNEL A		
5	VCCIN		
6	CHANNEL /C	Connection for Simulated Encoder	
7	CHANNEL C		
8	SHIELD		
9	GND		

TAB. 14 (Frequency output)

Simulated encoder feed can be different from 5V, up to 24V, in that case the power supply has to be external (VCCIN). Connect pin 9 (GND), the pin 5 (VCCIN) with external supply and **open the dip-switch present on the regulation board**.

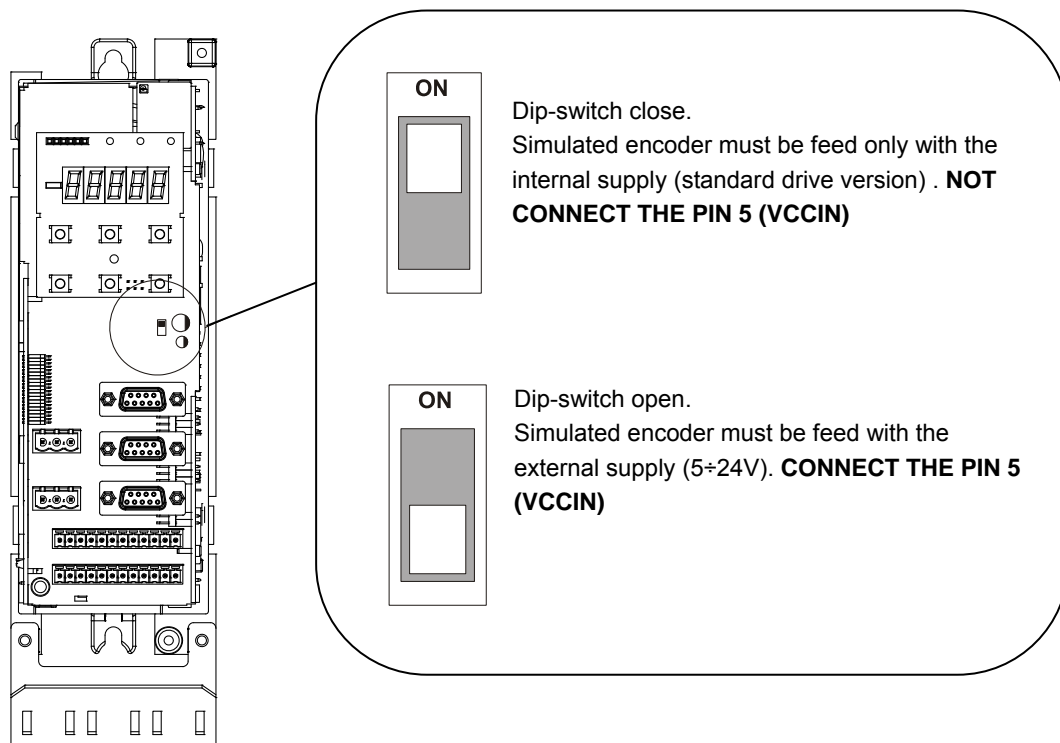

If the simulated encoder is fed by the internal supply the pin 5 (VCCIN) must not be connected, because it could seriously damage the drive.

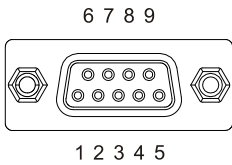

7.2.10.6 Frequency Input

J2 (Female)		
PIN	FUNCTION	DESCRIPTION
1	SHIELD	
2	--	
3	E-C	Channel C input if differential (otherwise not connected).
4	E-B	Channel B input if differential (otherwise not connected).
5	E-A	Channel A input if differential (otherwise not connected).
6	GND	0V
7	E-/C	Channel /C frequency input
8	E-/B	Channel /B frequency input or direction input (UP/Down).
9	E-/A	Channel /A frequency input or frequency input

TAB. 15 (Frequency Input)

7.2.10.7 Default I/O Configuration

INPUT	DEFAULT	CONNECTION
L.I.1	Alarms Reset.	C01 = 8
L.I.2	External consent.	C02 = 2
L.I.3	Enable 14 bit analog reference A.I.1	C03 = 3
L.I.4	Drive ON (power stage enabled).	C04 = 0
L.I.5	Enable 14 bit analog reference A.I.2.	C05 = 4
L.I.6	CW/CCW	C06 = 12
L.I.7	Enable speed jog.	C07 = 5
L.I.8	Enable linear ramps.	C08 = 22
OUTPUT	DEFAULT	CONNECTION
L.O.1	Drive switched on (power stage enabled).	C10 = 3
L.O.2	Drive ready.	C11 = 0
Relay	Speed higher than the minimum one.	C13 = 2
OUTPUT	DEFAULT	CONNECTION
VOUTA	Module of the current supplied by converter.	C15 = 11
VOUTB	Working frequency or motor speed.	C16 = 4

TAB. 16 (Default I/O configuration)

7.2.11 Feedback Options

7.2.11.1 Resolver

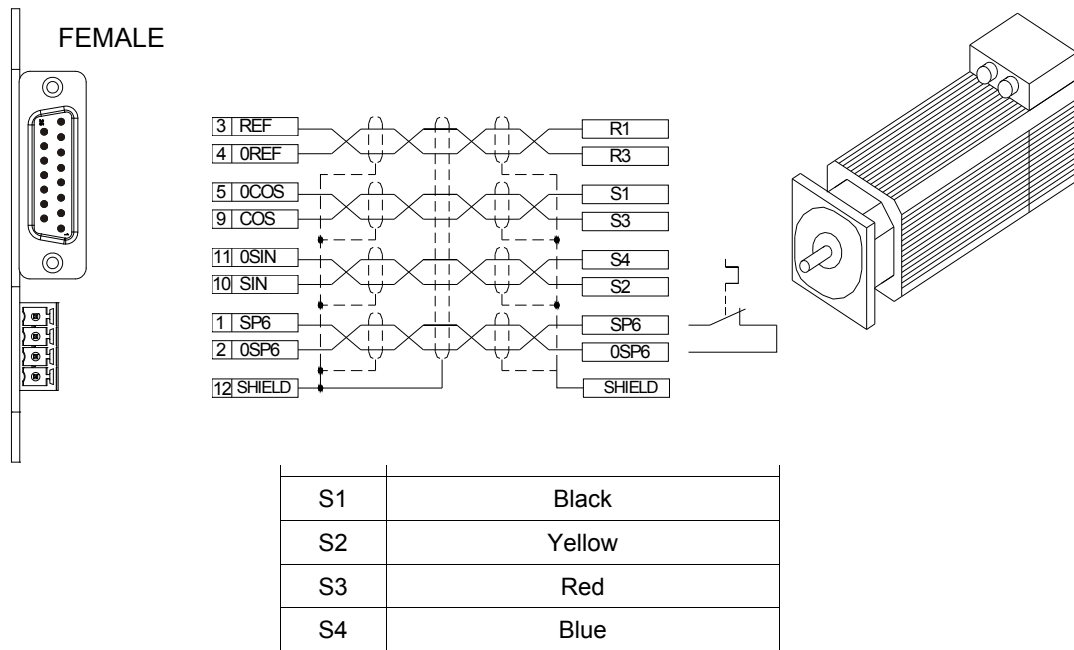

Example of Resolver colors code

Only use 4-couples twisted and shielded couple cable with external shield.

Pin 12 and the metallic body of connector on the feedback board are earthed inside the drive

By default the drive can manage a motor thermal switch (pin SP6 and 0SP6). Managing a different probe (PTC) is also possible connecting it to the M5 connector.

7.2.11.2 Encoder and Hall Sensors

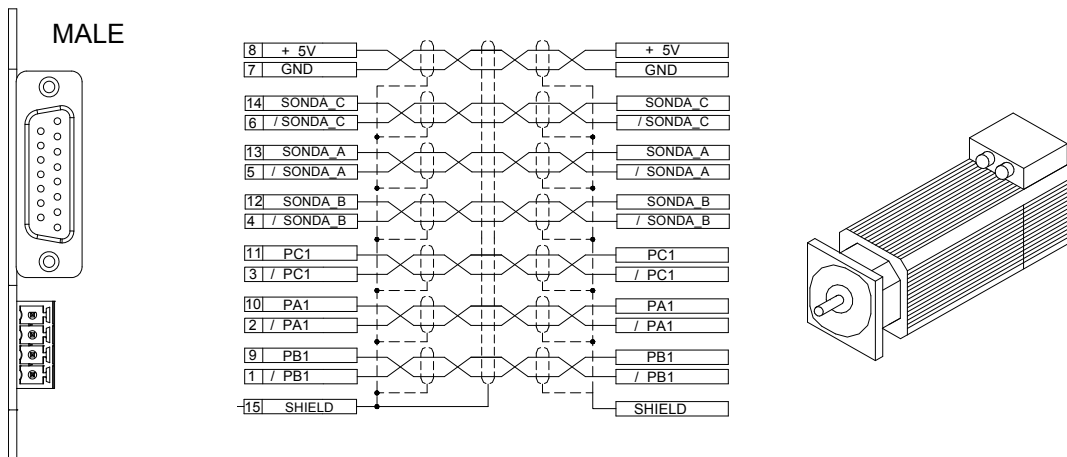

Only use 4-couples twisted and shielded couple cable with external shield.

Encoder feed is 5V and its differential output has to be “Line Driver”, with a number of pulses per revolution that do not exceed 300KHz for channel at maximum speed; current absorbed must not be above 100 mA.

Encoder feed can be different from 5V, up to 24V, in that case the power supply has to be external. Connect only drive pin 7 (GND) with external supply negative pole.

WARNING: for the encoder with internal supply (standard drive version) you must connect the terminal 8. Set the switch on the board as indicated in the follow image, dip1 position ON (closed) and leave dip2 OFF.

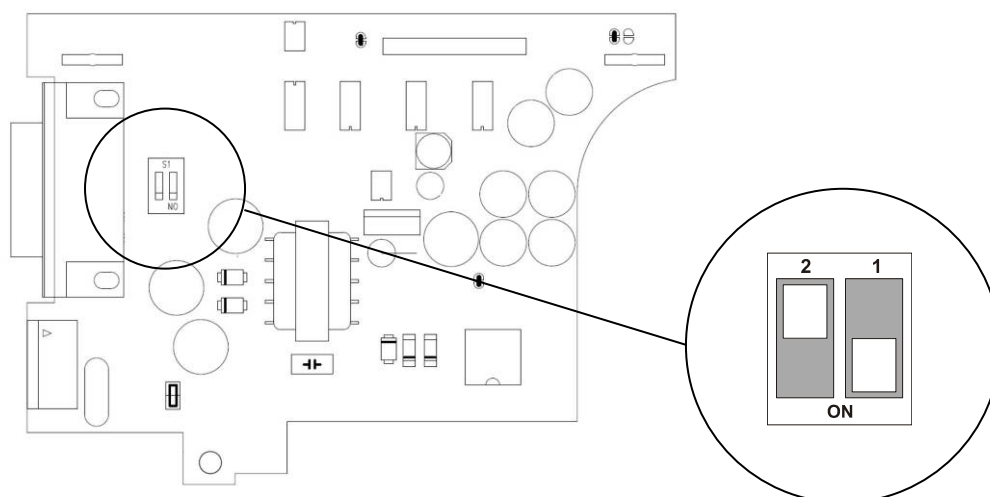

WARNING: for the encoder with external supply, you must not connect the terminal 8 (+5V), because it could seriously damage the drive. Set the switch on the board as indicated in the follow image, dip1 position OFF (open) and leave dip2 OFF.

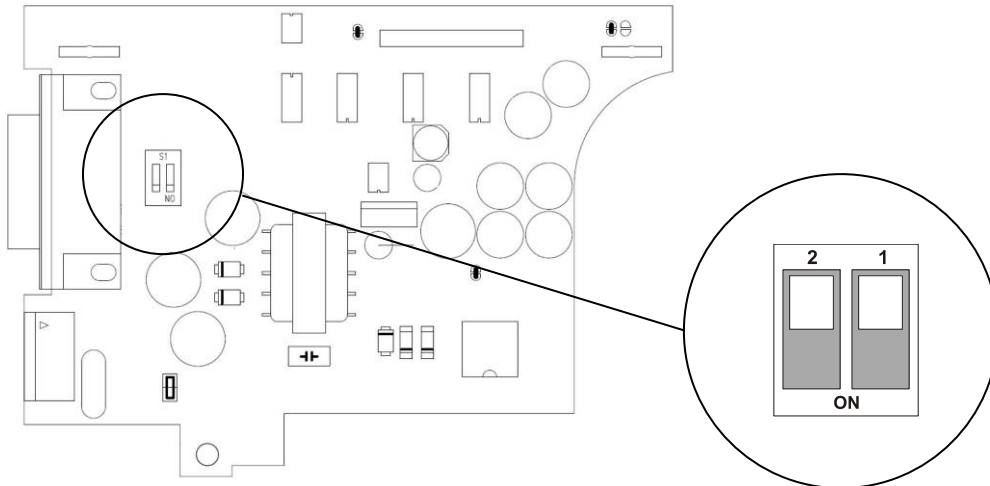

7.2.11.3 INCREMENTAL SIN COS ENCODER

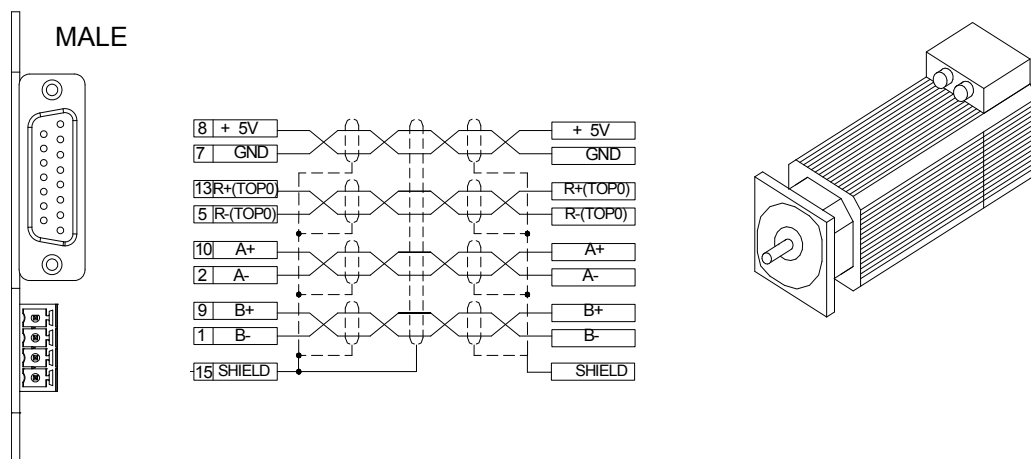

Only use 4-couples twisted and shielded couple cable with external shield.

Sin Cos Encoder feed is 5V with a number of pulses per revolution that do not exceed 300KHz for channel at maximum speed; current absorbed must not be above 100 mA.

7.2.11.4 Absolute SIN COS Encoder

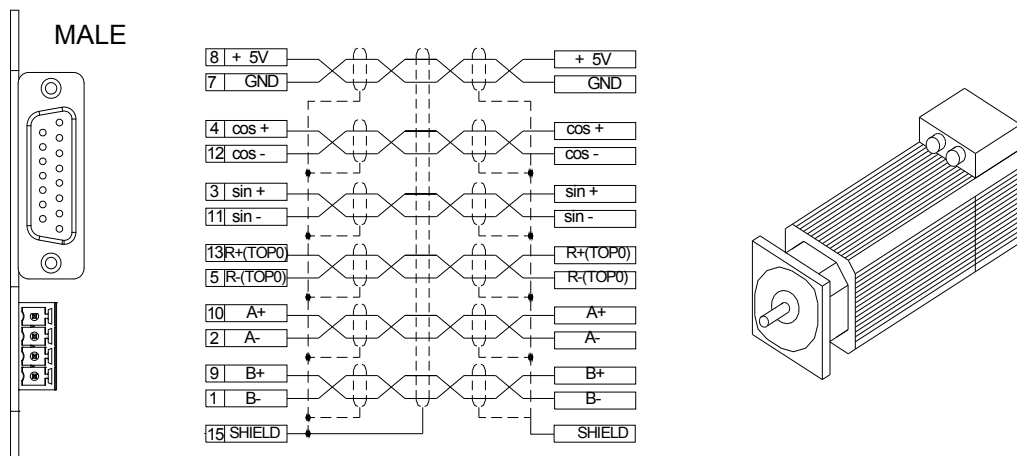

Only use 4-couples twisted and shielded couple cable with external shield.

Sin Cos Encoder feed is 5V with a number of pulses per revolution that do not exceed 300KHz for channel at maximum speed; current absorbed must not be above 100 mA

7.2.11.5 ENDAT 2.1

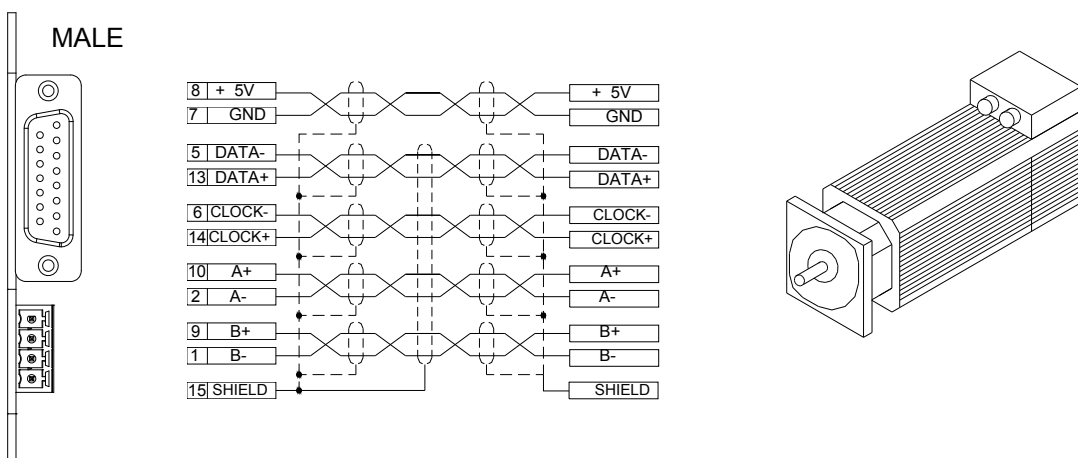

Only use 4-couples twisted and shielded couple cable with external shield.

5V DC current absorbed must not exceed 100 mA.

Up today the Endat 2.1 sensors managed are:

ECN 1113 with 13 bit on turn + 512 pulses sin/cos

EQN 1125 with 13 bit on turn, 12 bit multi-turn + 512 pulses sin/cos

ECN 1313 with 13 bit on turn + 512/2048 pulses sin/cos

EQN 1325 with 13 bit on turn, 12 bit multi-turn + 512/2048 pulses sin/cos

7.2.11.6 ENDAT 2.2 / BISS

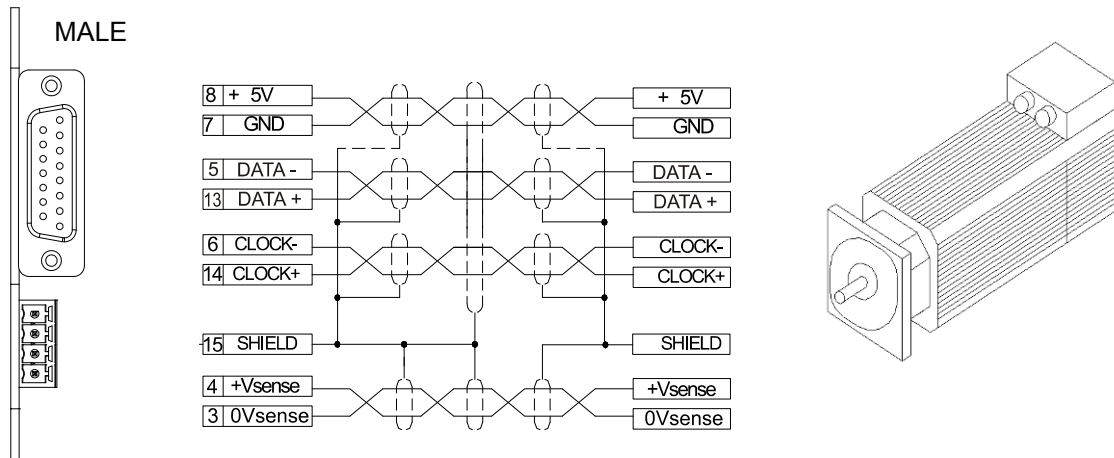

Only use 4-couples twisted and shielded couple cable with external shield.

5V DC current absorbed must not exceed 350 mA.

To compensate the voltage drop due to the length of the cable, connect pin "+ Vsense" and "0Vsense"

BiSS sensor managed:

AD36 1219 with 19 bit Single Turn, 12 bit Multi Turn.

ENDAT 2.2 sensors managed:

ECI 1317 with 17 bit on turn.

EQI 1329 with 17 bit on turn and 12 bit multi-turn.

7.3 OPTOISOLATED SERIAL LINE RS485

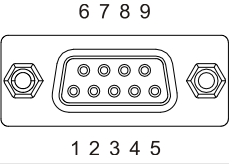
J3 (Female)		
	PIN	FUNCTION
1	GND	
2	TX	Trasmission pos
3	RX	Reception pos
4	--	
5	+TERM	Termination pos
6	/TX	Trasmission neg
7	/RX	Reception neg
8	--	
9	- TERM	Termination neg

TAB.17 (Serial line)

The serial line present on MiniOPD drives has connection capability for “4-wire” data transmission and therefore it can communicate in full-duplex mode. As a fact, by virtue of the protocol used (MODBUS RTU), it always communicates in “half-duplex” mode, wherefore you can make the connection with just “**two wires**” by connecting **RX** and **TX** and **/RX** and **/TX** between them. In connector J3, RX and /RX signals are the reception signals for the drive, while TX and /TX are the transmission signals.

Below is an example of connection to an USB port.

MiniOPD EXP

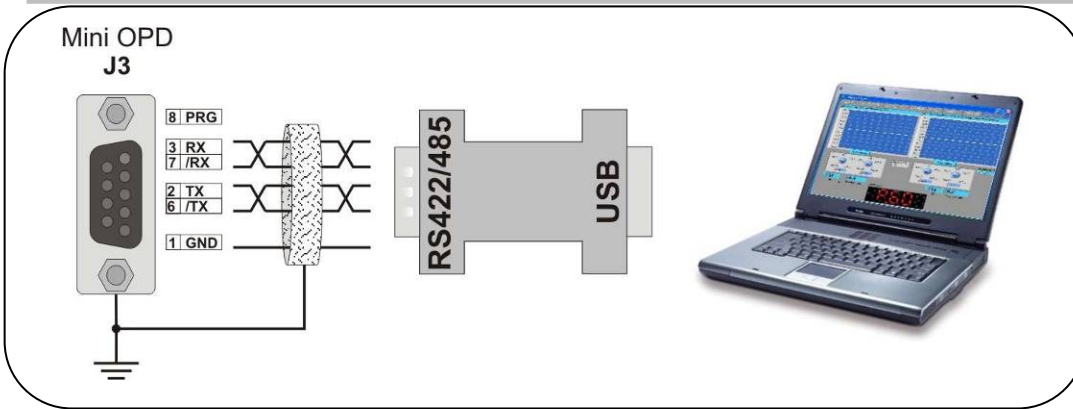

FIG. 18 (Example for connection with USB port)

Impedances are fitted inside the drive to “terminate” the connection (120Ω) and polarize the line, as shown in FIG. 19. To use this terminal, connect between them terminals 5 - 3 and 9 - 7 of connector J3 (for the last drive in the line only).

Communication wires must be twisted.

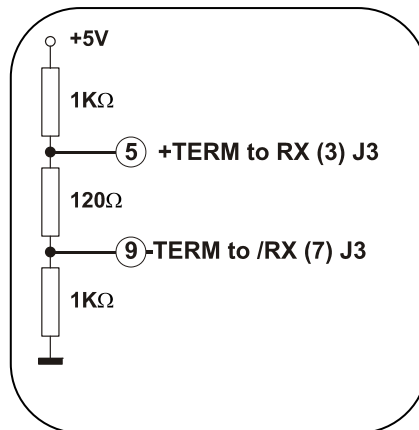

FIG. 19 (120Ω Connections)

7.4 LINE INPUT

Mod.	Minimum Inductance				
	Minimum Inductance (mH)	Thermal Current (A)	Peak Saturation Current (A)	Line Choke Code	TDE Macno Code
2-04	2,5	4,0	12	--	--
2-11	2	9,0	25	--	--
2-22	1,5	15	35	--	--
2-30	1	19	50	--	--
4-08	5.84	4.2	15.6	RETB0001	054RR001T
4-15	5.84	4.2	15.6	RETB0001	054RR001T
4-30	3.43	7.1	26.6	RETB0002	054RR002T

TAB 18 (Minimum inductance on the line input)

FEATURES OF INPUT FUSES		
MiniOPD EXP	Ultra-Fast Fuses (A)	Voltage (AC)
2-04	10-15	480
2-11	20-25	480
2-22	25-30	480
2-30	30-35	480
4-08	10-15	480
4-15	10-15	480
4-30	15-20	480

TAB 19 (Features of input fuses)

7.5 LINE OUTPUT

Mod.	Minimum Inductance				
	Minimum Inductance (mH)	Thermal Current (A)	Peak Saturation Current (A)	Line Choke Code	TDE Macno Code
2-04	1,28	3,3	7,1	--	--
2-11	0,54	7,7	16,7	--	--
2-22	0,32	13,3	28,6	--	--
2-30	0,32	13,3	28,6	--	--
4-08	2,214	3,3	7,1	054R39039	RET39039
4-15	0,949	7,7	16,7	054R39040	RET39040
4-30	0,949	7,7	16,7	054R39040	RET39040

TAB 20 (Minimum inductance on the line output)

8 CONNECTION/FIXING SHIELDS

Connect all cable shields relative to the sensors, the feedback, fieldbus, references (analog and frequency) and power to the bracket as shown in fig. 1.

Possible solutions:

- A- Cod. Wurth-Elektronik 7425131
- B- Cod Wurth-Elektronik 7425123
- C- Cod Phoenix 3026874

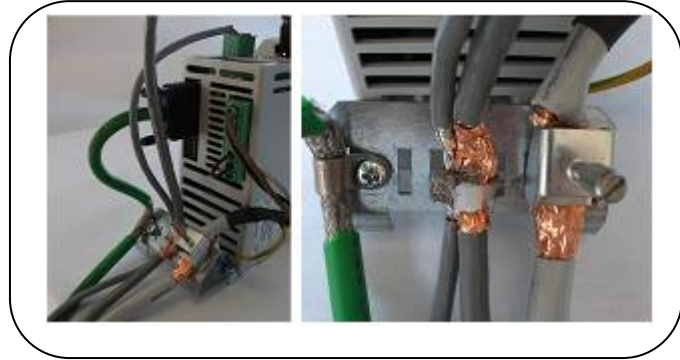

FIG. 1 (Drive side: examples of connection cable shields)

It is, also, necessary solder the cable shield relative to the sensor to the pin "SHIELD" and to the metallic covering, as shown in fig. 2. Connect the cable shield of each feedback, fieldbus and references (analog and frequency) with the SHIELD pin as shown in the installation manual schemes.

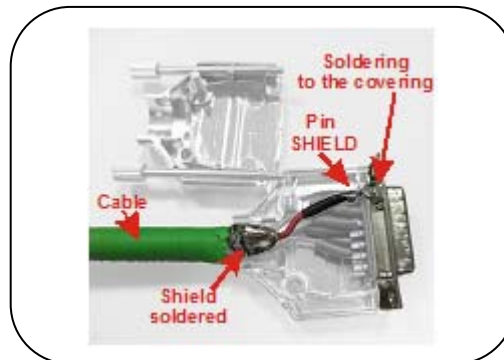

FIG. 2 (Drive side: connection shield in the connector)

Solder the shield to the ground wire of the engine as shown in fig.3.

Furthermore, the cable shield relative to the sensor must be connected to the pin shield of the own connector.



FIG. 3 (Drive side: example motor cable shield connection)

9 SAFETY

9.1 REFERENCE DIRECTIVES AND STANDARDS

The drive referred to herein has been designed and manufactured keeping in mind the considerations that emerged from a view to fulfilling the essential safety and health requirements as set forth in the European Directives, taking into account the existing state of the art. **TAB. 20** contains a list of the European Directives and Norms (EN) that were taken as reference.

REF.	NAME
2006/95/CE	<i>“Low Voltage Directive of the European Parliament and Council of 12 December 2006, on the approximation of the laws of the Member States relating to electrical equipment designed for use within certain voltage limits”.</i>
2004/108/CE	<i>“ Electromagnetic Compatibility Directive of the Council of 15 December 2004, on the approximation of the laws of the Member States relating to electromagnetic compatibility and repealing directive 89/336/CE”.</i>
EN 60204-1 : 2006	<i>“Fundamental safety standard relating to the electrical equipment of machines”.</i>
CEI EN 61800-3 :1996	<i>“Variable Speed Drives Part 3: Product standard relating to electromagnetic compatibility and special test procedures”.</i>
CEI EN 61800-5-2 : 2007	Part 5-2 Safety requirements - Functional”.
IEC 61800-5-1 : 2005	<i>“Semiconductor power converters for adjustable speed electric drive systems”.</i>

TAB. 21 (Reference directives and standards)

9.2 INTERFERENCE-SUPPRESSION MEASURES

Electric or electronic devices can interfere as a result of network connections or other metal connections.

In order to reduce or eliminate interference, the drive must be installed correctly and interference suppression measures should be taken whenever needed.

The instructions below refer to undisturbed power supply. In case of disturbances in the power mains, additional measures should be taken to reduce such disturbances.

In these cases, it is not possible to provide general instructions; if the measures taken to suppress disturbances should not prove sufficient, feel free to contact us.

- 1) Ensure that all devices inside the cabinet are properly connected to the ground bar, by means of short, star-connected wires. It is extremely important that all control devices connected to the converter, such as the PLC, be connected to the same ground via short wires.
- 2) The drive must be secured by means of screws and toothed washers so as to ensure a suitable electrical connection between the case and the metal support and must be connected to the panel ground; if needed, remove paint to guarantee proper contact.
- 3) Connect the motor by means of shielded or armored cables only and ground the shield on the converter side as well as on motor side. If shielded cables cannot be used, the motor cables should be placed in a metallic raceway connected to ground.
- 4) Ensure that the motor cables, converter cables and control ones are separated and well apart from each other.
- 5) Connect the braking resistor with a shielded cable and connect the shield to ground on both sides (converter and resistor side).
- 6) Control cables should be placed at least 10 cm away from power parallel cables, if any. Also in this case, we recommend using a separate metallic raceway properly grounded. If control cables have to cross the power cables, make sure they cross at 90-degree angles.
- 7) Fit RC units or a free-wheeling diode for contactor coils, relays or other electromechanical switches installed in the cabinet that houses the converter and mount them directly on the connections of the coils themselves.
- 8) Make all external control, measurement and regulation connections by means of shielded cables.
- 9) Cables that can propagate interferences should be laid separately and at a distance from the converter's control cables.

In addition to the above measures, if the converter is to operate in an environment very sensitive to electromagnetic noise, the following measures must be taken to reduce conducted and radiated interferences:

- 1) Fit a mains filter between the converter and the line; filter must be placed as close as possible to the converter, with the shortest possible connections.
- 2) If required, also fit a filter common mode choke between the converter and the motor and place it as close as possible to the converter.

TDE MACNO
s.p.a. tecnologie digitali elettroniche

Via dell'Oreficeria, 41 - 36100 VICENZA - Italy
Tel. +39 0444 343555 - Fax +39 0444 343509
www.tdemacno.it

TDE macno
s.p.a. tecnologie digitali elettroniche

Via dell'Oreficeria, 41 - 36100 VICENZA - Italy
Tel. +39 0444 343555 - Fax +39 0444 343509
www.tdemacno.it